

**Ministry of Public Works and Settlement
Government of Republic of Turkey**

Specification for Structures to be Built in Disaster Areas

**PART III - EARTHQUAKE DISASTER PREVENTION
(Chapter 5 through Chapter 13)**

Issued on: 2.9.1997, Official Gazette No.23098

Effective from: 1.1.1998

Amended on: 2.7.1998, Official Gazette No.23390

**ENGLISH TRANSLATION
PREPARED UNDER THE DIRECTION OF**

**M. Nuray AYDINOGLU, PhD.
Professor, Department of Earthquake Engineering
Bogazici University
Kandilli Observatory and Earthquake Research Institute
81220 Cengelkoy, Istanbul, Turkey
E-mail : aydinogn@boun.edu.tr**

PART III - EARTHQUAKE DISASTER PREVENTION

CHAPTER 5 - OBJECTIVE, GENERAL PRINCIPLES AND SCOPE

5.1. OBJECTIVE AND GENERAL PRINCIPLES

5.1.1 - The objective of this Part of the Specification is to define the minimum requirements for the earthquake resistant design and construction of buildings and building-like of structures or their parts subjected to earthquake ground motion.

5.1.2 - The general principle of earthquake resistant design to this Specification is to prevent structural and non-structural elements of buildings from any damage in low-intensity earthquakes; to limit the damage in structural and non-structural elements to repairable levels in medium-intensity earthquakes, and to prevent the overall or partial collapse of buildings in high-intensity earthquakes in order to avoid the loss of life.

5.1.3 - The design earthquake considered in this Specification corresponds to *high-intensity* earthquake defined in **5.1.2** above. For buildings with Building Importance Factor of **I=1** in accordance with **Chapter 6, Table 6.3**, the probability of exceedance of the design earthquake within a period of 50 years is 10 %.

5.1.4 - Seismic zones cited in this Specification are the first, second, third and fourth seismic zones depicted in *Seismic Zoning Map of Turkey* prepared by the Ministry of Public Works and Settlement and issued by the decree of the Council of Ministers.

5.2. SCOPE

5.2.1 - Requirements of this Specification shall be applicable to newly constructed buildings as well as to buildings to be modified, enlarged and to be repaired or strengthened prior to or following the earthquake.

5.2.2 - Requirements of this Specification shall be applicable to reinforced concrete (cast-in-situ and prestressed or non-prestressed prefabricated) buildings, structural steel buildings and building-like structures, and timber, masonry and adobe buildings.

5.2.3 - In addition to buildings and building-like structures, non-building structures permitted to be designed in accordance with the requirements of this Specification are limited with those specified in **6.12** of **Chapter 6**. In this context bridges, dams, harbour structures, tunnels, pipelines, power transmission lines, nuclear power plants, natural gas storage facilities, underground structures and other structures designed with analysis and safety rules that are different than those for buildings are outside the scope of this Specification.

5.2.4 - Requirements of this Specification shall not be applied to buildings equipped with special system and equipment between foundation and soil for the purpose of isolation of building structural system from the earthquake motion, and to buildings incorporating other active and passive control systems.

5.2.5 - Rules to be applied to structures which are outside the scope shall be specifically determined by the Ministries supervising the constructions and such structures shall be designed to those rules until their own special specifications are prepared.

CHAPTER 6 - ANALYSIS REQUIREMENTS FOR EARTHQUAKE RESISTANT BUILDINGS

6.0. NOTATION

- A(T)** = Spectral Acceleration Coefficient
A_o = Effective Ground Acceleration Coefficient
A_t = Equivalent area used for calculating the first natural vibration period [m²]
A_{wj} = Gross section area of j'th structural wall of the first storey of building [m²]
B_a = Design internal force component of a structural element in the direction of its principal axis **a**
B_{ax} = Internal force component of a structural element in the direction of its principal axis **a** due to earthquake in **x** direction
B_{ay} = Internal force component of a structural element in the direction of its principal axis **a** due to earthquake in **y** direction perpendicular to **x** direction
B_B = Any response quantity obtained by modal combination in the Mode-Superposition Method
B_D = Amplified value of **B_B**
C_t = Coefficient used for the approximate calculation of the first natural vibration period in the Equivalent Seismic Load Method
D_i = Amplification factor to be applied in Equivalent Seismic Load Method to $\pm 5\%$ additional eccentricity at i'th storey of a torsionally irregular building
d_{fi} = Displacement calculated at i'th storey of building under fictitious loads **F_{fi}**
d_i = Displacement calculated at i'th storey of building under design seismic loads
F_{fi} = Fictitious load acting at i'th storey in the determination of fundamental natural vibration period
F_i = Design seismic load acting at i'th storey in Equivalent Seismic Load Method
f_e = Equivalent seismic load acting at the mass centre of the mechanical and electrical equipment
g = Acceleration of gravity (9.81 m/s²)
g_i = Total dead load at i'th storey of building
H_i = Height of i'th storey of building measured from the top foundation level (In buildings with rigid peripheral basement walls, height of i'th storey of building measured from the top of ground floor level) [m]
H_N = Total height of building measured from the top foundation level (In buildings with rigid peripheral basement walls, total height of building measured from the top of the ground floor level) [m]
h_i = Height of i'th storey of building [m]
I = Building Importance Factor
ℓ_{wj} = Effective length of j'th structural wall in the first storey of building in the earthquake direction considered [m]
M_r = Modal mass of the r'th natural vibration mode
M_{xr} = Effective participating mass of the r'th natural vibration mode of building in the **x** earthquake direction considered
M_{yr} = Effective participating mass of the r'th natural vibration mode of building in the **y** earthquake direction considered
m_i = i'th storey mass of building (**m_i = w_i / g**)
m_{θi} = In the case where floors are modelled as rigid diaphragms, mass moment of inertia around vertical axis passing through unshifted mass centre of i'th storey of building
N = Total number of stories of building from the foundation level (In buildings with rigid peripheral basement walls, total number of stories from the ground floor level)

- n** = Live Load Participation Factor
q_i = Total live load at i'th storey of building
R = Structural Behaviour Factor
R_a(T) = Seismic Load Reduction Factor
R_{NC} = Structural Behaviour Factor defined in **Table 6.5** for the case where entire seismic loads are carried by frames of nominal ductility level
R_{YP} = Structural Behaviour Factor defined in **Table 6.5** for the case where entire seismic loads are carried by walls of high ductility level
S(T) = Spectrum Coefficient
S_{pa}(T_r) = Acceleration spectrum ordinate for the r'th natural vibration mode [m/s²]
T = Building natural vibration period [s]
T₁ = First natural vibration period of building [s]
T_{1A} = Empirically calculated first natural vibration period of building [s]
T_A, T_B = Spectrum Characteristic Periods [s]
T_r, T_s = r'th and s'th natural vibration periods of building [s]
V_i (*) = Storey shear at i'th storey of building in the earthquake direction considered
V_t = In the Equivalent Seismic Load Method, total equivalent seismic load acting on the building (base shear) in the earthquake direction considered
V_{tB} = In the Mode-Superposition Method, total design seismic load acting on the building (base shear) obtained by modal combination in the earthquake direction considered
W = Total weight of building calculated by considering Live Load Participation Factor
w_e = Weight of mechanical or electrical equipment
w_i = Weight of i'th storey of building by considering Live Load Participation Factor
Y = Sufficient number of natural vibration modes taken into account in the Mode-Superposition Method
α = Coefficient used for determining the gap size of a seismic joint
α_M (*) = Ratio of the sum of bending moments at the bases of structural walls of high ductility level to the base overturning moment of the entire building (In the calculation of bending moments at the wall bases, contribution of in-plane seismic shear forces developed at the ends of girders joining to walls may be considered)
β = Coefficient used to determine lower limits of response quantities calculated by Mode-Superposition Method
Δ_i = Storey drift of i'th storey of building
(Δ_i)_{max} = Maximum storey drift of i'th storey of building
(Δ_i)_{ort} = Average storey drift of i'th storey of building
ΔF_N = Additional equivalent seismic load acting on the N'th storey (top) of building
η_{bi} = Torsional Irregularity Factor defined at i'th storey of building
η_{ci} = Strength Irregularity Factor defined at i'th storey of building
η_{ki} = Stiffness Irregularity Factor defined at i'th storey of building
Φ_{xir} = In buildings with floors modelled as rigid diaphragms, horizontal component of r'th mode shape in the x direction at i'th storey of building
Φ_{yir} = In buildings with floors modelled as rigid diaphragms, horizontal component of r'th mode shape in the y direction at i'th storey of building
Φ_{θir} = In buildings with floors modelled as rigid diaphragms, rotational component of r'th mode shape around the vertical axis at i'th storey of building
θ_i = Second Order Effect Indicator defined at i'th storey of building

(*) Amended on July 2, 1998. Official Gazette No.23390.

6.1. SCOPE

6.1.1 - Seismic loads and analysis requirements to be applied to the earthquake resistant design of all cast-in-situ and prefabricated reinforced concrete buildings, structural steel buildings and building-like structures to be built in seismic zones defined in **5.1.4** of **Chapter 5** are specified in this chapter. Rules for timber, masonry and adobe buildings are specified in **Chapter 9**, **Chapter 10** and **Chapter 11**, respectively.

6.1.2 - Rules for the analysis of building foundations and soil retaining structures are specified in **Chapter 12**.

6.1.3 - Non-building structures which are permitted to be analysed in accordance with the requirements of this chapter shall be limited to those given in **Section 6.12**.

6.2. GENERAL GUIDELINES AND RULES

6.2.1. General Guidelines for Building Structural Systems

6.2.1.1 – The building structural system resisting seismic loads as a whole as well as each structural element of the system shall be provided with sufficient stiffness, stability and strength to ensure an uninterrupted and safe transfer of seismic loads down to the foundation soil. In this respect, it is essential that floor systems possess sufficient stiffness and strength to ensure the safe transfer of lateral seismic loads between the elements of the structural system.

6.2.1.2 - In order to dissipate a significant part of the seismic energy fed into the structural system, *ductile design* principles specified in **Chapter 7** and in **Chapter 8** of this Specification should be followed.

6.2.1.3 - Design and construction of irregular buildings defined in **6.3.1** below should be avoided. Structural system should be arranged symmetrical or nearly symmetrical in plan and torsional irregularity defined as type **A1** irregularity in **Table 6.1** should preferably be avoided. In this respect, it is essential that stiff structural elements such as structural walls should be placed so as to increase the torsional stiffness of the building. On the other hand, vertical irregularities defined as types **B1** and **B2** in **Table 6.1** leading to *weak storey* or *soft storey* at any storey should be avoided. In this respect, appropriate measures should be taken to avoid the negative effects of abrupt decreases in stiffness and strength due to removal of infill walls from some of the stories and in particular from the first storey of buildings which may possess considerable stiffness in their own planes, even though they are not taken into account in the analysis.

6.2.1.4 - Effects of rotations of column and in particular wall supporting foundations on soils classified as group **(C)** and **(D)** in **Table 12.1** of **Chapter 12** should be taken into account by appropriate methods of structural modelling.

6.2.2. General Rules for Seismic Loads

6.2.2.1 - Unless specified otherwise in this chapter, seismic loads acting on buildings shall be based on *Spectral Acceleration Coefficient* specified in **6.4** and *Seismic Load Reduction Factor* specified in **6.5**.

6.2.2.2 - Unless specified otherwise in this Specification, seismic loads shall be assumed to act non-simultaneously along the two perpendicular axes of the building in the horizontal plane. In the cases where the principal axes of the vertical structural elements do not coincide with the earthquake directions, **6.3.2.3** shall be applied.

6.2.2.3 - Unless specified otherwise in this Specification, load factors to be used to determine design internal forces under the combined effects of seismic loads and other loads according to *ultimate strength theory* shall be taken from the relevant structural specifications.

6.2.2.4 - It shall be assumed that the wind loads and seismic loads act non-simultaneously, and the most unfavourable response quantity due to wind or earthquake shall be considered for the design of each structural element. However even if the quantities due to wind govern, rules given in this Specification shall be applied for dimensioning and detailing of structural elements and their joints.

6.3. IRREGULAR BUILDINGS

6.3.1. Definition of Irregular Buildings

Regarding the definition of irregular buildings whose design and construction should be avoided because of their unfavourable seismic behaviour, types of irregularities in plan and in elevation are given in **Table 6.1** and relevant conditions are given in **6.3.2** below.

6.3.2. Conditions for Irregular Buildings

Conditions related to irregularities defined in **Table 6.1** are given below:

6.3.2.1 - Irregularity types **A1** and **B2** govern the selection of the method of seismic analysis as specified in **6.6** below.

6.3.2.2 - In buildings with irregularity types **A2** and **A3**, it shall be verified by calculation in the first and second seismic zones that the floor systems are capable of safe transfer of seismic loads between vertical structural elements.

6.3.2.3 - In buildings with irregularity type **A4**, internal forces along the principal axes of structural elements shall be determined in accordance with **6.7.5** and **6.8.6**.

6.3.2.4 - In buildings with irregularity type **B1**, if total infill wall area at *i*'th storey is greater than that of the storey immediately above, then infill walls shall not be taken into account in the determination of η_{ci} . In the range $0.60 \leq (\eta_{ci})_{\min} < 0.80$, Structural Behaviour Factor, **R**, given in **Table 6.5** shall be multiplied by $1.25 (\eta_{ci})_{\min}$ which shall be applicable to the entire building in both earthquake directions. In no case, however, $\eta_{ci} < 0.60$ shall be permitted. Otherwise strength and stiffness of the weak storey shall be increased and the seismic analysis shall be repeated. Furthermore, in buildings with such irregularity, requirement given in **7.3.4.3** shall be applied.

TABLE 6.1 - IRREGULAR BUILDINGS

A – IRREGULARITIES IN PLAN	Related Items
<p><u>A1 – Torsional Irregularity :</u> The case where <i>Torsional Irregularity Factor</i> η_{bi}, which is defined for any of the two orthogonal earthquake directions as the ratio of the maximum storey drift at any storey to the average storey drift at the same storey in the same direction, is greater than 1.2 (Fig. 6.1). [$\eta_{bi} = (\Delta_i)_{\max} / (\Delta_i)_{\text{ort}} > 1.2$] <i>Storey drifts shall be calculated in accordance with 6.7, by Considering the effects of \pm %5 additional eccentricities.</i></p>	6.3.2.1
<p><u>A2 – Floor Discontinuities :</u> In any floor (Fig. 6.2); I - The case where the total area of the openings including those of stairs and elevator shafts exceeds 1/3 of the gross floor area, II – The cases where local floor openings make it difficult the safe transfer of seismic loads to vertical structural elements, III – The cases of abrupt reductions in the in-plane stiffness and strength of floors.</p>	6.3.2.2
<p><u>A3 – Projections in Plan :</u> The cases where projections beyond the re-entrant corners in both of the two principal directions in plan exceed the total plan dimensions of the building in the respective directions by more than 20%. (Fig. 6.3).</p>	6.3.2.2
<p><u>A4 – Nonparallel Axes of Structural Elements :</u> The cases where the principal axes of vertical structural elements in plan are not parallel to the orthogonal earthquake directions considered (Fig. 6.4).</p>	6.3.2.3
B – IRREGULARITIES IN ELEVATION	Related Items
<p><u>B1 – Interstorey Strength Irregularity (Weak Storey) :</u> In reinforced concrete buildings, the case where in each of the Orthogonal earthquake directions, <i>Strength Irregularity Factor</i> η_{ci} which is defined as the ratio of the <i>effective shear area</i> of any storey to the <i>effective shear area</i> of the storey immediately above, is less than 0.80. [$\eta_{ci} = (\sum A_e)_i / (\sum A_e)_{i+1} < 0.80$] <i>Definition of effective shear area in any storey :</i> $\sum A_e = \sum A_w + \sum A_g + 0.15 \sum A_k$ (See 7.0 for notations)</p>	6.3.2.4
<p><u>B2 – Interstorey Stiffness Irregularity (Soft Storey) :</u> The case where in each of the two orthogonal earthquake directions, <i>Stiffness Irregularity Factor</i> η_{ki}, which is defined as the ratio of the average storey drift at any storey to the average storey drift at the storey immediately above, is greater than 1.5. $[\eta_{ki} = (\Delta_i)_{\text{ort}} / (\Delta_{i+1})_{\text{ort}} > 1.5]$ <i>Storey drifts shall be calculated in accordance with 6.7, by considering the effects of \pm %5 additional eccentricities.</i></p>	6.3.2.1
<p><u>B3 - Discontinuity of Vertical Structural Elements :</u> The cases where vertical structural elements (columns or structural walls) are removed at some stories and supported by beams or gusseted columns underneath, or the structural walls of upper stories are supported by columns or beams underneath (Fig. 6.6).</p>	6.3.2.5

6.3.2.5 - Conditions related to buildings with irregularities of type **B3** are given below:

(a) In all seismic zones, columns at any storey of the building shall in no case be permitted to rest on the cantilever beams or on top of or at the tip of gussets provided in the columns underneath.

(b) In the case where a column rests on a beam which is supported at both ends, all internal force components induced by the combined vertical loads and seismic loads in the earthquake direction considered shall be increased by 50% at all sections of the beam and at all sections of the other beams and columns adjoining to the beam.

(c) In the case where both ends of a structural wall rest on columns underneath, all internal force components induced at such columns by the combined vertical loads and seismic loads shall be increased by 50%. In reinforced concrete buildings with such irregularity, the requirement given in 7.3.4.3 shall also be applied.

(d) Structural walls shall in no case be permitted in their own plane to rest on the beam span at any storey of the building.

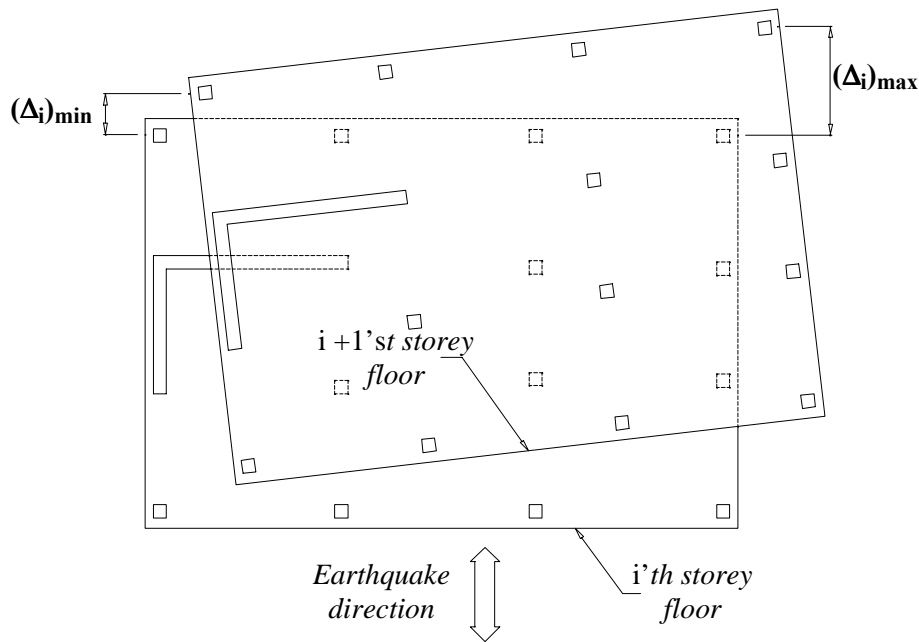

*In the case where floors behave as rigid diaphragms
in their own planes:*

$$(\Delta_i)_{ort} = 1/2 [(\Delta_i)_{max} + (\Delta_i)_{min}]$$

Torsional irregularity factor :

$$\eta_{bi} = (\Delta_i)_{max} / (\Delta_i)_{ort}$$

Torsional irregularity : $\eta_{bi} > 1.2$

Figure 6.1



$$A_b = A_{b1} + A_{b2}$$

Type A2 irregularity - I

$$A_b / A > 1/3$$

A_b : Total area of openings

A : Gross floor area

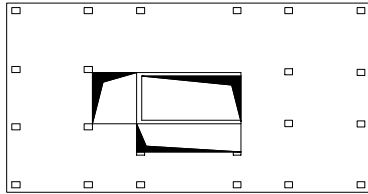

Type A2 irregularity - II

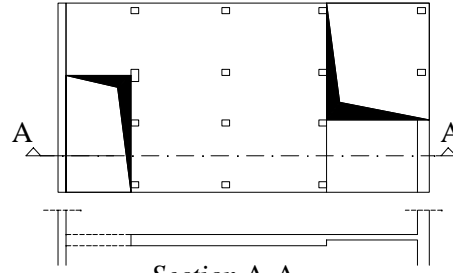

Section A-A

Type A2 irregularity - II and III

Figure 6.2

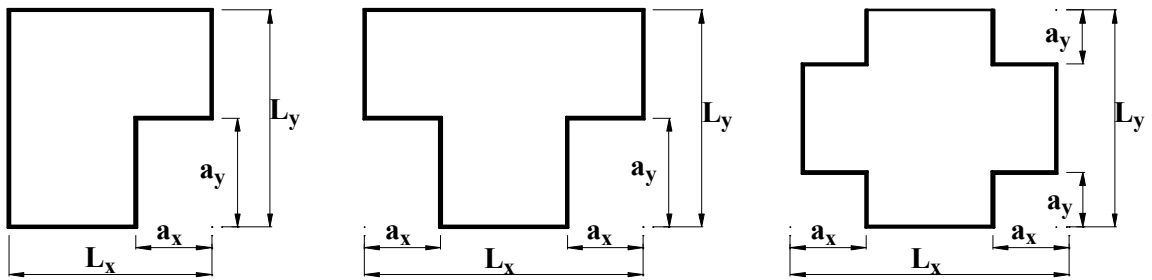

Type A3 irregularity :

$$a_x > 0.2 L_x \text{ and at the same time } a_y > 0.2 L_y$$

Figure 6.3

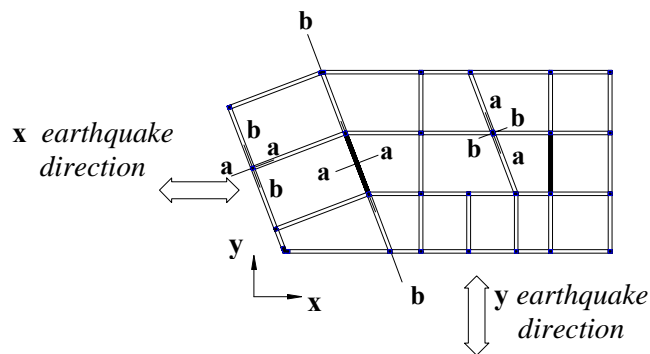
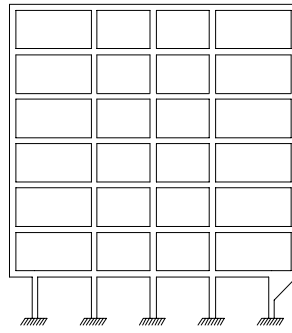
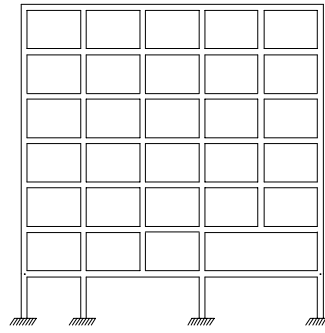

Figure 6.4



See 6.3.2.5 (a)



See 6.3.2.5 (b)

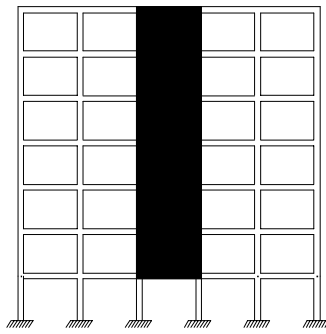

See 6.3.2.5 (c)

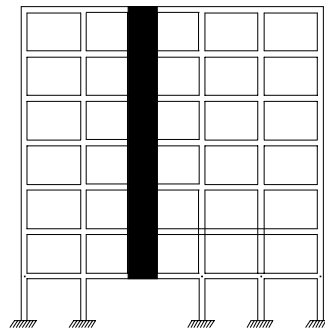

See 6.3.2.5 (d)

Figure 6.5

6.4. DEFINITION OF ELASTIC SEISMIC LOADS : SPECTRAL ACCELERATION COEFFICIENT

The *Spectral Acceleration Coefficient*, $A(T)$, corresponding to 5% damped elastic *Design Acceleration Spectrum* normalised by the acceleration of gravity, g , is given by **Eq.(6.1)** which shall be considered as the basis for the determination of seismic loads.

$$A(T) = A_0 I S(T) \quad (6.1)$$

6.4.1. Effective Ground Acceleration Coefficient

The *Effective Ground Acceleration Coefficient*, A_0 , appearing in **Eq.(6.1)** is specified in **Table 6.2**.

TABLE 6.2 - EFFECTIVE GROUND ACCELERATION COEFFICIENT (A_0)

<i>Seismic Zone</i>	A_0
1	0.40
2	0.30
3	0.20
4	0.10

6.4.2. Building Importance Factor

The *Building Importance Factor*, I , appearing in **Eq.(6.1)** is specified in **Table 6.3**.

TABLE 6.3 - BUILDING IMPORTANCE FACTOR (I)

<i>Purpose of Occupancy or Type of Building</i>	<i>Importance Factor (I)</i>
<p><u>1. Buildings to be utilised after the earthquake and buildings containing hazardous materials</u> a) Buildings required to be utilised immediately after the earthquake (Hospitals, dispensaries, health wards, fire fighting buildings and facilities, PTT and other telecommunication facilities, transportation stations and terminals, power generation and distribution facilities; governorate, county and municipality administration buildings, first aid and emergency planning stations) b) Buildings containing or storing toxic, explosive and flammable materials, etc.</p>	1.5
<p><u>2. Intensively and long-term occupied buildings and buildings preserving valuable goods</u> a) Schools, other educational buildings and facilities, dormitories and hostels, military barracks, prisons, etc. b) Museums</p>	1.4
<p><u>3. Intensively but short-term occupied buildings</u> Sport facilities, cinema, theatre and concert halls, etc.</p>	1.2
<p><u>4. Other buildings</u> Buildings other than above defined buildings. (Residential and office buildings, hotels, building-like industrial structures, etc.)</p>	1.0

6.4.3. Spectrum Coefficient

6.4.3.1 - The *Spectrum Coefficient*, $S(T)$, appearing in **Eq.(6.1)** shall be determined by **Eqs.(6.2)**, depending on the local site conditions and the building natural period, T (**Fig.6.6**):

$$\begin{aligned}
 S(T) &= 1 + 1.5 T / T_A && (0 \leq T \leq T_A) && \text{(6.2a)} \\
 S(T) &= 2.5 && (T_A < T \leq T_B) && \text{(6.2b)} \\
 S(T) &= 2.5 (T_B / T)^{0.8} && (T > T_B) && \text{(6.2c)}
 \end{aligned}$$

Spectrum Characteristic Periods, T_A and T_B , appearing in **Eq.(6.2)** are specified in **Table 6.4**, depending on *Local Site Classes* defined in **Table 12.2** of **Chapter 12**.

TABLE 6.4 - SPECTRUM CHARACTERISTIC PERIODS (T_A , T_B)

<i>Local Site Class acc. to Table 12.2</i>	T_A (second)	T_B (second)
Z1	0.10	0.30
Z2	0.15	0.40
Z3	0.15	0.60
Z4	0.20	0.90

6.4.3.2 - In case where the requirements specified in **12.2.1.2** and **12.2.1.3** of **Chapter 12** are not met, spectrum characteristic periods defined in **Table 6.4** for local site class **Z4** shall be used.

6.4.4. Special Design Acceleration Spectra

When required, elastic acceleration spectrum may be determined through special investigations by considering local seismic and site conditions. However spectral acceleration coefficients corresponding to so obtained acceleration spectrum ordinates shall in no case be less than those determined by **Eq.(6.1)** based on relevant characteristic periods specified in **Table 6.4**.

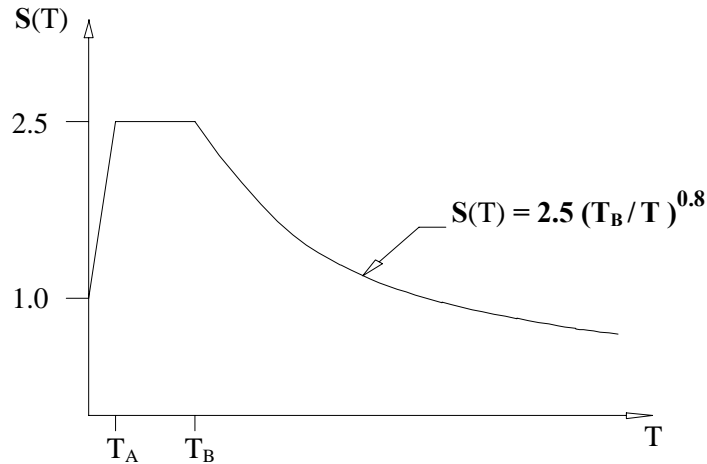

Figure 6.6

6.5. REDUCTION OF ELASTIC SEISMIC LOADS : SEISMIC LOAD REDUCTION FACTOR

Elastic seismic loads to be determined in terms of *spectral acceleration coefficient* defined in 6.4 shall be divided to below defined *Seismic Load Reduction Factor* to account for the specific nonlinear behaviour of the structural system during earthquake.

Seismic Load Reduction Factor, $R_a(T)$, shall be determined by **Eqs.(6.3)** in terms of *Structural Behaviour Factor*, R , defined in **Table 6.5** below for various structural systems, and the natural vibration period T .

$$R_a(T) = 1.5 + (R - 1.5) T / T_A \quad (0 \leq T \leq T_A) \quad (6.3a)$$

$$R_a(T) = R \quad (T > T_A) \quad (6.3b)$$

6.5.1. General Conditions on Ductility Levels of Structural Systems

6.5.1.1 - Definitions of and requirements to be fulfilled for *structural systems of high ductility level* and *structural systems of nominal ductility level* whose Structural Behaviour Factors are given in **Table 6.5**, are given in **Chapter 7** for reinforced concrete buildings and in **Chapter 8** for structural steel buildings.

6.5.1.2 - In structural systems denoted as being *high ductility level* in **Table 6.5**, ductility levels shall be high in both lateral earthquake directions. Systems of high ductility level in one earthquake direction and of nominal ductility level in the perpendicular earthquake direction shall be deemed to be *structural systems of nominal ductility level* in both directions.

TABLE 6.5 - STRUCTURAL BEHAVIOUR FACTORS (R)

<i>BUILDING STRUCTURAL SYSTEM</i>	<i>Systems of Nominal Ductility Level</i>	<i>Systems of High Ductility Level</i>
<u>(1) CAST-IN-SITU REINFORCED CONCRETE BUILDINGS</u>		
(1.1) Buildings in which seismic loads are fully resisted by frames.....	4	8
(1.2) Buildings in which seismic loads are fully resisted by coupled structural walls.....	4	7
(1.3) Buildings in which seismic loads are fully resisted by solid structural walls.....	4	6
(1.4) Buildings in which seismic loads are jointly resisted by frames and solid and/or coupled structural walls.....	4	7
<u>(2) PREFABRICATED REINFORCED CONCRETE BUILDINGS</u>		
(2.1) Buildings in which seismic loads are fully resisted by frames with connections capable of cyclic moment transfer	3	6
(2.2) Buildings in which seismic loads are fully resisted by single-storey hinged frames with fixed-in bases.....	—	5
(2.3) Buildings in which seismic loads are fully resisted by prefabricated solid structural walls.....	—	4
(2.4) Buildings in which seismic loads are jointly resisted by frames with connections capable of cyclic moment transfer and cast-in-situ solid and/or coupled structural walls	3	5
<u>(3) STRUCTURAL STEEL BUILDINGS</u>		
(3.1) Buildings in which seismic loads are fully resisted by frames.....	5	8
(3.2) Buildings in which seismic loads are fully resisted by single-storey hinged frames with fixed-in bases.....	4	6
(3.3) Buildings in which seismic loads are fully resisted by braced frames or cast-in-situ reinforced concrete structural walls		
(a) <i>Centrically braced frames</i>	3	—
(b) <i>Eccentrically braced frames</i>	—	7
(c) <i>Reinforced concrete structural walls</i>	4	6
(3.4) Buildings in which seismic loads are jointly resisted by frames and braced frames or cast-in-situ reinforced concrete structural walls		
(a) <i>Centrically braced frames</i>	4	—
(b) <i>Eccentrically braced frames</i>	—	8
(c) <i>Reinforced concrete structural walls</i>	4	7

6.5.1.3 - In the first and second seismic zones, *structural systems of high ductility level* shall be used for the following reinforced concrete buildings:

- (a) Buildings with structural systems comprised of frames only,

(b) Irrespective of the structural system, all buildings with Building Importance Factor of $I=1.5$ and $I=1.4$ according to **Table 6.3** (In such buildings, structural systems with *mixed ductility level* defined in **6.5.4.2** may be used).

6.5.1.4 - Excluding the systems indicated in **6.5.3.1** below, reinforced concrete buildings comprised only of *frames of nominal ductility level* are permitted to be built in the third and fourth seismic zones on the condition that $H_N \leq 25$ m. In order that such buildings can be built for $H_N > 25$ m, conditions given in **6.5.3.2** below shall be met.

6.5.2. Conditions for Solid Structural Wall-Frame Systems of High Ductility Level

Requirements for buildings where seismic loads are jointly resisted by reinforced concrete solid structural walls of *high ductility level* and reinforced concrete or structural steel frames of *high ductility level* are given below:

6.5.2.1 - In order that $R = 7$ can be used for such systems as it is given in **Table 6.5**, sum of bending moments developed at the bases of solid structural walls under seismic loads shall not exceed **75%** of the total overturning moment developed for the entire building ($\alpha_M \leq 0.75$).

6.5.2.2 - In the case where the above given requirement cannot be satisfied, coefficient R shall be calculated from the expression $R = 10 - 4\alpha_M$ in the range $0.75 < \alpha_M \leq 1.0$.

6.5.3. Conditions on Mandatory Use of Structural Walls in Certain Systems of Nominal Ductility Level

6.5.3.1 - Bare or infilled joist and waffle slab systems whose columns and beams do not satisfy the requirements given in **7.3**, **7.4** and **7.5**, and reinforced concrete flat slab systems shall be treated as *systems of nominal ductility level*. Without using structural walls, such systems can be built only in the third and fourth seismic zones on the condition that $H_N \leq 13$ m.

6.5.3.2 - In order that buildings defined above in **6.5.1.4** can be built for $H_N > 25$ m, and in order that buildings defined in **6.5.3.1** can be built in the first and second seismic zones as well as in the third and fourth seismic zones for $H_N > 13$ m, solid or coupled structural walls of nominal or high ductility level shall be used along the full height of the building with the following conditions fulfilled:

(a) When structural walls of *nominal ductility level* are used in the structural system, sum of bending moments developed at the bases of structural walls under seismic loads shall be more than **75%** of the total overturning moment developed for the entire building in each earthquake direction (In the calculation of bending moments at the wall bases, contribution of in-plane seismic shear forces developed at the ends of girders joining to the walls may be considered (*)).

(b) When structural walls of *high ductility level* are used in the structural system, requirements specified in **6.5.4.2** below for mixed structural systems shall be applied.

(*). Amended on July 2, 1998. Official Gazette No.23390.

6.5.4. Conditions for Mixed Structural Systems

6.5.4.1 - Excluding the cases given below in **6.5.4.2** and **6.5.4.3**, in the cases where lateral load carrying structural systems defined in **Table 6.5** are different in the two lateral earthquake directions or where those systems are mixed in any direction, the smallest value of **R** factor shall be applied to the entire building in both directions.

6.5.4.2 - Reinforced concrete systems mentioned in **6.5.3.2** as well as structural steel frame systems composed of beams and columns of *nominal ductility level* are permitted to be mixed with structural walls (or braced frames) of *high ductility level*. In so obtained *systems of mixed ductility level*, solid or coupled reinforced concrete structural walls, or for steel buildings eccentric braced frames may be used provided that the following conditions are met.

(a) In the analysis of such mixed systems, frames and structural walls (or braced frames) shall be jointly considered, however in each earthquake direction it shall be $\alpha_M \geq 0.40$.

(b) In the case where $\alpha_M \geq 2/3$ in both earthquake directions, **R** factor defined in **Table 6.5** for the case where seismic loads are fully resisted by structural walls (or braced frames) of *high ductility level* ($R=R_{YP}$), may be used for the entire structural system.

(c) In the range $0.40 < \alpha_M < 2/3$, the expression $R = R_{NC} + 1.5 \alpha_M (R_{YP} - R_{NC})$ shall be applied to the entire structural system in both earthquake directions.

6.5.4.3 - Reinforced concrete rigid peripheral walls used in basements of buildings shall not be taken into consideration as parts of structural wall systems or structural wall-frame systems appearing in **Table 6.5**. Rules to be applied to such buildings are given in **6.7.2.4** and **6.8.3.2**.

6.5.5. Conditions for Systems with Hinged Connections

6.5.5.1 - A single mezzanine floor can be constructed inside the prefabricated reinforced concrete and structural steel buildings made of single storey frames with columns fixed-in at the base and hinged at the top whose **R** factors are given in Items **(2.2)** and **(3.2)** of **Table 6.5**. Structural system of mezzanine floor shall be taken into account in the seismic analysis of such buildings together with the main structural frames. This system shall be made of high ductility level in prefabricated reinforced concrete buildings.

6.5.5.2 - With the exception of **6.5.5.1** above, in the reinforced concrete and structural steel multi-storey buildings with hinge connections, reinforced concrete cast-in-situ structural walls or steel braced frames whose **R** factors are given in Items **(1.2)**, **(1.3)** and **(3.3)** of **Table 6.5** shall be used to resist the entire seismic loads in both directions.

6.6. SELECTION OF ANALYSIS METHOD

6.6.1. Analysis Methods

Methods to be used for the seismic analysis of buildings and building-like structures are, *Equivalent Seismic Load Method* given in **6.7**, *Mode-Superposition Method* given

in 6.8 and *Analysis Methods in the Time Domain* given in 6.9. Methods given in 6.8 and 6.9 may be used for the seismic analysis of all buildings and building-like structures.

6.6.2. Application Limits of Equivalent Seismic Load Method

Buildings for which *Equivalent Seismic Load Method* given in 6.7 is applicable are summarised in Table 6.6. Methods given in 6.8 or 6.9 shall be used for the seismic analysis of buildings outside the scope of Table 6.6.

TABLE 6.6 - BUILDINGS FOR WHICH EQUIVALENT SEISMIC LOAD METHOD IS APPLICABLE

<i>Seismic Zone</i>	<i>Type of Building</i>	<i>Total Height Limit</i>
1, 2	Buildings without type A1 torsional irregularity, or those satisfying the condition $\eta_{bi} \leq 2.0$ at every storey	$H_N \leq 25$ m
1, 2	Buildings without type A1 torsional irregularity, or those satisfying the condition $\eta_{bi} \leq 2.0$ at every storey and at the same time without type B2 irregularity	$H_N \leq 60$ m
3, 4	All buildings	$H_N \leq 75$ m

6.7. EQUIVALENT SEISMIC LOAD METHOD

6.7.1. Determination of Total Equivalent Seismic Load

6.7.1.1 - *Total Equivalent Seismic Load* (base shear), V_t , acting on the entire building in the earthquake direction considered shall be determined by Eq.(6.4).

$$V_t = W A(T_1) / R_a(T_1) \geq 0.10 A_0 I W \quad (6.4)$$

The first natural vibration period of the building, T_1 , shall be calculated in accordance with 6.7.4 below.

6.7.1.2 - Total building weight, W , to be used in Eq.(6.4) as the seismic weight shall be determined by Eq.(6.5).

$$W = \sum_{i=1}^N w_i \quad (6.5)$$

Storey weights w_i of Eq.(6.5) shall be calculated by Eq.(6.6).

$$w_i = g_i + n q_i \quad (6.6)$$

Live Load Participation Factor, n , appearing in Eq.(6.6) is given in Table 6.7. 30% of snow loads shall be considered as dead loads. In industrial buildings, $n = 1$ shall be taken for fixed equipment weights while crane payloads shall not be taken into account in the calculation of storey weights.

TABLE 6.7 - LIVE LOAD PARTICIPATION FACTOR (n)

<i>Purpose of Occupancy of Building</i>	n
Depot, warehouse, etc.	0.80
School, dormitory, sport facility, cinema, theatre, concert hall, carpark, restaurant, shop, etc.	0.60
Residence, office, hotel, hospital, etc.	0.30

6.7.2. Determination of Design Seismic Loads Acting at Storey Levels

6.7.2.1 - Total equivalent seismic load determined by Eq.(6.4) is expressed by Eq. (6.7) as the sum of equivalent seismic loads acting at storey levels (Fig. 6.7a):

$$V_t = \Delta F_N + \sum_{i=1}^N F_i \quad (6.7)$$

6.7.2.2 - In the case $H_N > 25 \text{ m}$, *additional equivalent seismic load*, ΔF_N , acting at the N'th storey (top) of the building shall be determined by Eq.(6.8) depending on the first natural vibration period of the building, T_1 . It shall be $\Delta F_N = 0$ for $H_N \leq 25 \text{ m}$.

$$\Delta F_N = 0.07 T_1 V_t \leq 0.2 V_t \quad (6.8)$$

6.7.2.3 - Excluding ΔF_N , remaining part of the total equivalent seismic load shall be distributed to stories of the building (including N'th storey) in accordance with Eq.(6.9).

$$F_i = (V_t - \Delta F_N) \frac{w_i H_i}{\sum_{j=1}^N (w_j H_j)} \quad (6.9)$$

6.7.2.4 - In buildings with reinforced concrete peripheral walls at their basements being very rigid relative to upper stories and basement floors behaving as rigid diaphragms in horizontal planes, equivalent seismic loads acting on the basement stories and on the upper stories shall be calculated independently as in the following.

(a) In determining the total equivalent seismic load and equivalent storey seismic loads in accordance with 6.7.1.1, 6.7.2.2 and 6.7.2.3, appropriate **R** factor shall be selected from **Table 6.5** without considering the rigid peripheral basement walls and seismic weights of the upper stories only shall be taken into account. In this case, foundation top level appearing in the relevant definitions and expressions shall be replaced by the ground floor level. Fictitious loads used for the calculation of the first natural vibration period in accordance with 6.7.4.3 shall also be based on seismic weights of the upper stories only (Fig.6.7b).

(b) In calculating equivalent seismic loads acting on rigid basement stories, seismic weights of basements only shall be taken into account and calculation shall be independent of upper stories. For such parts of the building, *Spectrum Coefficient* shall be taken as $S(T) = 1$ without calculating the natural vibration period. In determining equivalent seismic loads acting on each basement storey, spectral acceleration obtained from Eq.(6.1) shall be multiplied directly with the respective weight of the storey and resulting elastic loads shall be reduced by dividing them to $R_a(T) = 1.5$ (Fig.6.7c).

(c) Internal forces and displacements in upper stories are the response quantities obtained from the analysis of the complete system in accordance with above given para. (a) only. On the other hand, internal forces at basement stories shall be obtained as *square roots of the sum of squares* of internal forces calculated under seismic loads defined in para. (a) and (b) above.

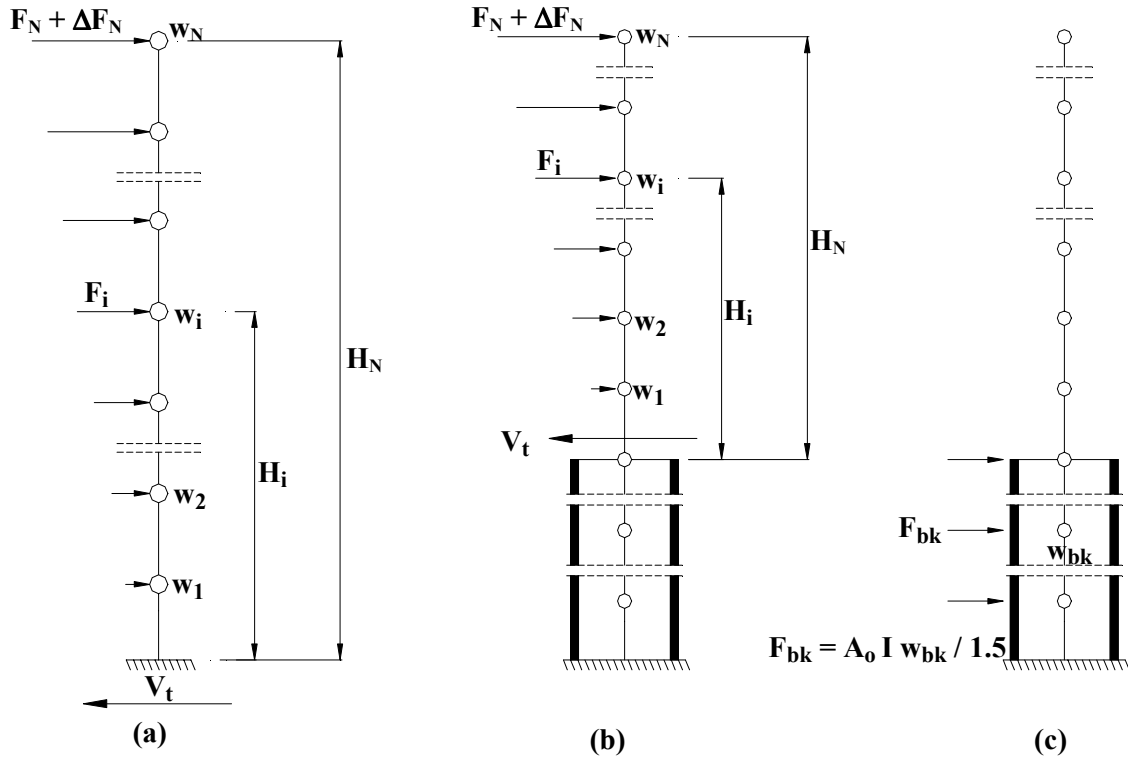

Figure 6.7

6.7.3. Displacement Components to be Considered and Application Points of Seismic Loads

6.7.3.1 - In buildings where floors behave as rigid horizontal diaphragms, two lateral displacement components and the rotation around the vertical axis shall be taken into account at each floor as independent static displacement components. At each floor, equivalent seismic loads determined in accordance with 6.7.2 shall be applied in the form of concentrated loads to the floor mass centre as well as to *shifted mass centres* to account for the *additional eccentricity effects*. Shifted mass centres are the points obtained by shifting the actual mass centre by + 5% and – 5% times the floor length in the perpendicular direction to the earthquake direction considered (Fig. 6.8).

6.7.3.2 - In buildings where type A2 irregularity exists and floors do not behave as rigid horizontal diaphragms, sufficient number of independent static displacement components shall be considered to account for the in-plane deformation of floors. In order to consider additional eccentricity effects, each of the individual masses distributed over each floor shall be shifted by + 5% and – 5% times the floor length in perpendicular direction to the earthquake direction considered (Fig. 6.9).

6.7.3.3 - In the case where type A1 irregularity defined in Table 6.1 exists at any i 'th storey such that the condition $1.2 < \eta_{bi} \leq 2.0$ is satisfied, above defined $\pm 5\%$ additional eccentricity applied to this floor shall be amplified by multiplying with coefficient D_i given by Eq.(6.10) for both earthquake directions.

$$D_i = (\eta_{bi} / 1.2)^2 \quad (6.10)$$

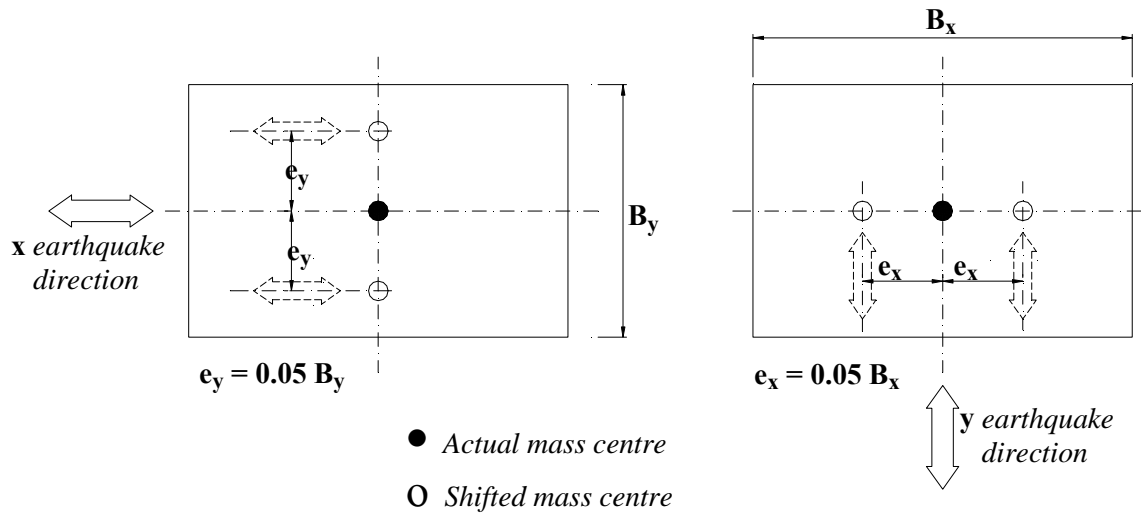
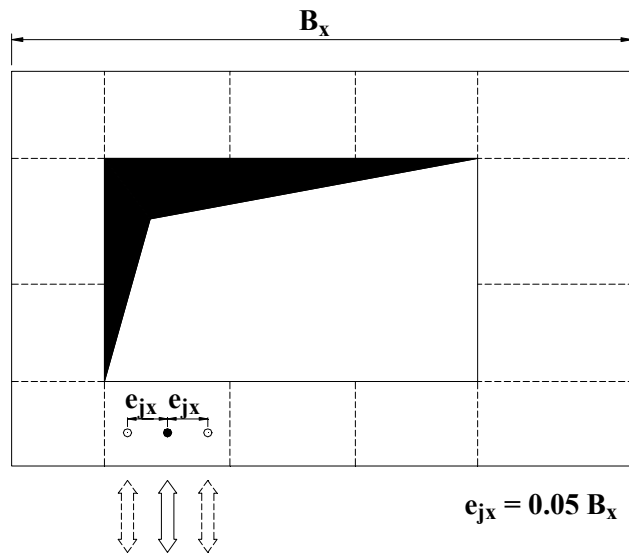

Figure 6.8



- Actual mass centre of the j 'th floor segment
- o Shifted mass centre of the j 'th floor segment

Figure 6.9

6.7.4. Determination of First Natural Vibration Period of Building

6.7.4.1 - In all buildings to which Equivalent Seismic Load Method is applied, the first natural vibration period may be calculated in accordance with below given **6.7.4.3**. However, the first natural vibration period is permitted to be calculated by the approximate method given in **6.7.4.2** for buildings with $H_N \leq 25$ m in the first and second seismic zones and for all buildings to which Equivalent Seismic Load Method is applied in the third and fourth seismic zones. In the case where $H_N > 25$ m in the first and second seismic zones, the application of **6.7.4.3** is mandatory.

6.7.4.2 - Considering the conditions given in **6.7.4.1** above, the first natural vibration period of the building may be calculated by the following approximate expression:

$$T_1 \cong T_{1A} = C_t H_N^{3/4} \quad (6.11)$$

Values of C_t in Eq.(6.11) are defined below depending on the building structural system

(a) The value of C_t shall be calculated by Eq.(6.12) for buildings where seismic loads are fully resisted by reinforced concrete structural walls.

$$C_t = 0.075 / A_t^{1/2} \leq 0.05 \quad (6.12a)$$

Equivalent area A_t appearing in Eq.(6.12a) is given by Eq.(6.12b) where the maximum value of (ℓ_{wj}/H_N) shall be taken equal to 0.9.

$$A_t = \sum_j A_{wj} [0.2 + (\ell_{wj} / H_N)^2] \quad (6.12b)$$

(b) It shall be $C_t = 0.07$ for buildings whose structural system are composed only of reinforced concrete frames or structural steel eccentric braced frames, $C_t = 0.08$ for buildings made only of steel frames, $C_t = 0.05$ for all other buildings.

6.7.4.3 - Considering the conditions given in **6.7.4.1** above, unless a more refined analysis is performed, the first natural vibration period of the building shall be calculated by Eq.(6.13) and the resulting value shall be limited in accordance with **6.7.4.4** below.

$$T_1 = 2 \pi \left[\sum_{i=1}^N (m_i d_{fi}^2) / \sum_{i=1}^N (F_{fi} d_{fi}) \right]^{1/2} \quad (6.13)$$

In this expression, m_i represents the mass of the i 'th storey ($m_i = w_i / g$). F_{fi} refers to the fictitious load acting on the i 'th storey which is obtained from Eq.(6.9) by substituting any value (*for example unit value*) in place of $(V_t - \Delta F_N)$, see Fig. 6.10. At each storey, fictitious loads shall be applied in accordance with **6.7.3.1** to actual (*unshifted*) mass centres in the earthquake direction considered or to individual masses in accordance with **6.7.3.2**. d_{fi} represents displacements calculated at the same points under such loads in the given earthquake direction.

6.7.4.4 - The first natural vibration period of the building shall also be calculated in accordance with **6.7.4.2**, and in the case $T_{1A} > 1.0$ s according to Eq.(6.11), the maximum value of T_1 obtained from Eq.(6.13) shall not exceed 1.30 times T_{1A} .

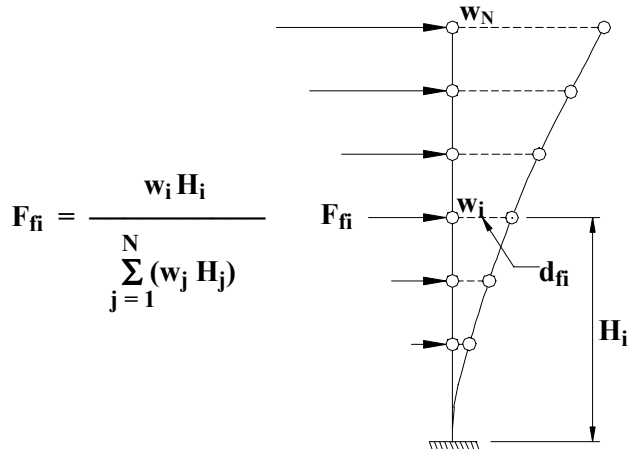

Figure 6.10

6.7.5. Response Quantities of Structural Elements with Principle Axes Nonparallel to Earthquake Directions

In buildings where type A4 irregularity defined in Table 6.1 exists, internal forces along the principal axes of structural elements shall be determined in accordance with Eqs.(6.14), see Fig.6.4.

$$B_a = \pm B_{ax} \pm 0.30 B_{ay} \quad (6.14a)$$

$$B_a = \pm 0.30 B_{ax} \pm B_{ay} \quad (6.14b)$$

The above operations shall be performed for both axis **a** and perpendicular axis **b**, by considering both **x** and **y** earthquake directions and senses to yield the most unfavourable results.

6.8. MODE SUPERPOSITION METHOD

In this method, maximum internal forces and displacements are determined by the statistical combination of maximum contributions obtained from each of the sufficient number of natural vibration modes considered.

6.8.1. Acceleration Spectrum

Acceleration spectrum ordinate to be taken into account in any *r*'th vibration mode shall be determined by Eq.(6.15).

$$S_{pa}(T_r) = A(T_r) g / R_a(T_r) \quad (6.15)$$

In the case where elastic design acceleration spectrum is determined through special investigations in accordance with 6.4.4, relevant spectrum ordinate shall be considered in Eq.(6.15) in lieu of $A(T_r) g$.

6.8.2. Dynamic Degrees of Freedom to be Considered

6.8.2.1 - In buildings where floors behave as rigid horizontal diaphragms, two horizontal degrees of freedom in perpendicular directions and a rotational degree of freedom with respect to the vertical axis passing through *each of the shifted mass centres* shall be considered at each storey. Storey masses shall be defined at the mass centre as well as at *shifted mass centres* of each storey to account for the *additional*

eccentricity effects. Shifted mass centres are the points obtained by shifting the actual mass centre by +5% and –5% of the floor length in perpendicular direction to the earthquake direction considered (Fig. 6.8). However, mass moment of inertia of the i 'th storey, $m_{\theta i}$, shall be calculated with respect to the vertical axis passing through *unshifted mass centre*. Storey weights corresponding to storey masses shall be determined in accordance with 6.7.1.2.

6.8.2.2 - In buildings where type A2 irregularity exists and floors do not behave as rigid horizontal diaphragms, sufficient number of dynamic degrees of freedom shall be considered to account for the in-plane deformation of floors. In order to consider additional eccentricity effects, each of the individual masses distributed over each floor shall be shifted by +5% and –5% of the floor length in perpendicular direction to the earthquake direction considered (Fig. 6.9). In such buildings, internal force and displacement quantities due to additional eccentricity effects alone may also be calculated in accordance with 6.7. Such quantities shall be directly added to those combined in accordance with below given 6.8.4 without taking into account additional eccentricity effects.

6.8.3. Sufficient Number of Vibration Modes to be Considered

6.8.3.1 - *Sufficient number of vibration modes*, Y , to be taken into account in the analysis shall be determined to the criterion that the sum of effective participating masses calculated for each mode in each of the given x and y lateral earthquake directions perpendicular to each other shall in no case be less than 90% of the total building mass. In the earthquake direction considered, all vibration modes with effective participating masses exceeding 5% of the total building mass shall also be taken into account.

$$\sum_{r=1}^Y M_{xr} = \sum_{r=1}^Y \left\{ \left[\sum_{i=1}^N (m_i \Phi_{xir}) \right]^2 / M_r \right\} \geq 0.90 \sum_{i=1}^N m_i \quad (6.16a)$$

$$\sum_{r=1}^Y M_{yr} = \sum_{r=1}^Y \left\{ \left[\sum_{i=1}^N (m_i \Phi_{yir}) \right]^2 / M_r \right\} \geq 0.90 \sum_{i=1}^N m_i \quad (6.16b)$$

The expression of M_r appearing in Eqs.(6.16) is given below for buildings where floors behave as rigid diaphragms:

$$M_r = \sum_{i=1}^N (m_i \Phi_{xir}^2 + m_i \Phi_{yir}^2 + m_{\theta i} \Phi_{\theta ir}^2) \quad (6.17)$$

6.8.3.2 - In buildings with reinforced concrete peripheral walls at their basements being very rigid relative to upper stories and basement floors behaving as rigid diaphragms in horizontal planes, it may be sufficed with the consideration of vibration modes which are effective in the upper stories only. In this case, in the analysis performed by the Mode Superposition Method which corresponds to the analysis by Equivalent Seismic Load Method as given in Para.(a) of 6.7.2.4, the coefficient R shall be selected from Table 6.5 without considering the rigid peripheral basement walls whereas the upper storey masses only shall be taken into account. Para. (b), (c) and (d) of 6.7.2.4 shall be applied as they are given for Equivalent Seismic Load Method.

6.8.4. Modal Combination

Rules to be applied for the statistical combination of non-simultaneous maximum contributions of response quantities calculated for each vibration mode, such as the base shear, storey shear, internal force components, displacement and storey drift, are specified in the following *provided that they are applied independently for each response quantity*:

6.8.4.1 - In the cases where natural periods of any two vibration mode with $T_s < T_r$ always satisfy the condition $T_s / T_r < 0.80$, *Square Root of Sum of Squares (SRSS) Rule* may be applied for the combination of maximum modal contributions.

6.8.4.2 - In the cases where the above given condition is not satisfied, *Complete Quadratic Combination (CQC) Rule* shall be applied for the combination of maximum modal contributions. In the calculation of *cross correlation coefficients* to be used in the application of the rule, modal damping factors shall be taken as 5% for all modes.

6.8.5. Lower Limits of Response Quantities

In the case where the ratio of the base shear in the given earthquake direction, V_{tB} , which is obtained through modal combination according to **6.8.4**, to the base shear, V_t , obtained by Equivalent Seismic Load Method through **Eq.6.4** is less than the below given value of β ($V_{tB} < \beta V_t$), all internal force and displacement quantities determined by Mode Superposition Method shall be amplified in accordance with **Eq.(6.18)**.

$$B_D = (\beta V_t / V_{tB}) B_B \quad (6.18)$$

In the case where at least one of the irregularities of type **A1**, **B2** or **B3** defined in **Table 6.1** exists in a building $\beta=1.00$, whereas none of them exists $\beta=0.90$ shall be used in **Eq. (6.18)**.

6.8.6. Response Quantities of Structural Elements with Principle Axes Nonparallel to Earthquake Directions

In the case where principle axes of some of the structural elements are not parallel to the orthogonal earthquake directions, directional combination rule given in **6.7.5** shall be applied additionally to the internal forces of such elements combined in accordance with **6.8.4**.

6.9. ANALYSIS METHODS IN TIME DOMAIN

6.9.1 - In special cases, previously recorded or *artificially simulated ground motions* may be used for the linear or nonlinear analysis of buildings and building-like structures in the time domain.

6.9.2 - At least three acceleration records, previously recorded or generated in accordance with the following properties shall be used for the seismic analysis to be performed in the time domain, and the most unfavourable response quantities shall be considered in the design.

(a) The duration of strong motion part of the acceleration record in which acceleration envelopes are not to be less than $\pm 0.05 g$, shall neither be less than 5 times the first natural vibration period of the building nor less than 15 seconds.

(b) Spectral acceleration values recalculated for each recorded or simulated acceleration record with 5% damping ratio shall not be less than 90% of the spectral acceleration coefficient, $A(T)$, defined in 6.4 times the acceleration of gravity, g , for the whole period range. In the case where linear elastic analysis is performed in the time domain, spectral acceleration values to be considered for the reduced ground motion shall be calculated by Eq.(6.15).

6.9.3 - In the case where nonlinear analysis is performed in the time domain, dynamic stress-strain relationships defining the nonlinear behaviour of the structural system shall be determined by theoretically or experimentally proven methods in line with the overall philosophy of this Specification.

6.10. LIMITATION OF DISPLACEMENTS, SECOND ORDER EFFECTS AND SEISMIC JOINTS

6.10.1. Limitation of Storey Drifts

6.10.1.1 - The *storey drift*, Δ_i , of any column or structural wall shall be determined by Eq.(6.19) as the difference of displacements between the two consecutive stories.

$$\Delta_i = d_i - d_{i-1} \quad (6.19)$$

In Eq.(6.19) d_i and d_{i-1} represent lateral displacements obtained from the analysis at the ends of any column or structural wall at stories i and $(i - 1)$.

6.10.1.2 - The maximum value of storey drifts within a storey, $(\Delta_i)_{\max}$, calculated by Eq.(6.19) for columns and structural walls of the i 'th storey of a building for each earthquake direction shall satisfy the unfavourable one of the conditions given by Eqs.(6.20):

$$(\Delta_i)_{\max} / h_i \leq 0.0035 \quad (6.20a)$$

$$(\Delta_i)_{\max} / h_i \leq 0.02 / R \quad (6.20b)$$

6.10.1.3 - In the cases where the conditions specified by Eqs.(6.20) are not satisfied at any storey, the earthquake analysis shall be repeated by increasing the stiffness of the structural system. The serviceability of nonstructural brittle elements such as façade elements shall be verified by calculation even if the above given conditions satisfied.

6.10.2. Second-Order Effects

Unless a more refined analysis considering the nonlinear behaviour of structural system is performed, second-order effects may be taken into account according to 6.10.2.1.

6.10.2.1 - In the case where *Second-Order Effect Indicator*, θ_i , satisfies the condition given by Eq.(6.21) for the earthquake direction considered at each storey, second-order effects shall be evaluated in accordance with currently enforced specifications of reinforced concrete or structural steel design.

$$\theta_i = \frac{(\Delta_i)_{ort} \sum_{j=i}^N w_j}{V_i h_i} \leq 0.12 \quad (6.21)$$

Here $(\Delta_i)_{ort}$ shall be determined in accordance with **6.10.1.1** as the average value of storey drifts calculated for i 'th storey columns and structural walls.

6.10.2.2 - In the case where the condition given by **Eq.(6.21)** is not satisfied, seismic analysis shall be repeated by sufficiently increasing the stiffness of the structural system.

6.10.3. Seismic Joints

Excluding the effects of differential settlements and rotations of foundations and the effects of temperature change, sizes of gaps to be retained in the seismic joints between building blocks or between the old and newly constructed buildings shall be determined in accordance with the following conditions:

6.10.3.1 - Unless a larger value is obtained in accordance with **6.10.3.2** below, sizes of gaps shall not be less than the sum of the absolute values of average storey displacements multiplied by the coefficient α specified below. Storey displacements to be considered are the average values of those calculated within a storey at the column or structural wall joints. In cases where the seismic analysis is not performed for the existing old building, the storey displacements shall not be assumed to be less than those obtained for the new building at the same stories.

(a) $\alpha = R / 4$ if all floor levels of adjacent buildings or building blocks are the same.

(b) $\alpha = R / 2$ if any of the floor levels of adjacent buildings or building blocks are not the same.

6.10.3.2 - Minimum size of gaps shall be **30 mm** up to **6 m** height. From thereon a minimum **10 mm** shall be added for each **3 m** height increment.

6.10.3.3 - Seismic joints shall be arranged to allow the independent movement of building blocks in all earthquake directions.

6.11. SEISMIC LOADS APPLIED TO STRUCTURAL APPENDAGES, ARCHITECTURAL ELEMENTS, MECHANICAL AND ELECTRICAL EQUIPMENT

6.11.1. Seismic Loads Applied to Structural Appendages and Architectural Elements

Seismic loads to be applied to structural appendages such as balconies, parapets, chimneys, etc. and to all architectural elements such as façade and partition panels, etc. shall be determined as the product of the weight of the relevant element and the spectral acceleration coefficient obtained from **Eq.(6.1)** with $S(T)=1.0$. The resulting seismic

load shall be applied to the tip of the relevant element in the *horizontal or vertical direction* to yield the most unfavourable internal forces.

6.11.2. Seismic Loads Applied to Mechanical and Electrical Equipment

6.11.2.1 - Horizontal seismic loads to be used for the analysis of mechanical and electrical equipment and their connections to the building structural system shall be determined by **Eq.(6.22)**. However, in the case where the sum of weights of mechanical or electrical equipment (indicated by w_e in **Eq.(6.22)**) at any i 'th storey is greater than $0.2w_i$, equipment weights and stiffness properties of their connections shall be taken into account in the structural analysis.

$$f_e = w_e A_0 I (1 + H_i / H_N) \quad (6.22)$$

6.11.2.2 – Twice the seismic load obtained from **Eq.(6.22)** shall be considered in the analysis of boilers and burners of central heating systems, emergency electric and fire fighting systems, for all equipment attached to the infill walls and for their connections.

6.11.2.3 - **Eq.(6.22)** may not be applied in industrial buildings where *floor acceleration spectrum* is determined by appropriate methods defining the peak acceleration at the floor where mechanical or electrical equipment are located.

6.12. NON-BUILDING STRUCTURES

Non-building structures permitted to be analysed in accordance with the requirements of this chapter and the corresponding *Structural Behaviour Factors*, (**R**), to be applied to such structures are given in **Table 6.8**. Applicable Seismic Load Reduction Factors shall be determined in accordance with **Eq.(6.3)**.

Where applicable, *Building Importance Factors* specified in **Table 6.3** shall be used for non-building structures. However *Live Load Participation Factors* specified in **Table 6.7** shall not be applied. Except snow loads and crane payloads, unreduced weights of all solid and liquid materials stored and mechanical equipment shall be used.

6.13. REQUIREMENTS FOR SEISMIC ANALYSIS REPORTS

The following requirements shall apply to the analysis reports that include seismic analysis of buildings:

6.13.1 - Types of irregularities specified in **Table 6.1** shall be evaluated in detail for the building to be designed and, if any, existing irregularities shall be identified.

6.13.2 - The selected structural system of high or nominal ductility level shall be clearly defined with respect to the requirements of **Chapter 7** or **Chapter 8**, and the selection of the applicable **R** factor from **Table 6.5** shall be explained.

6.13.3 - The selection of the applicable analysis method in accordance with **6.6** shall be clearly explained by considering the seismic zone, building height and structural irregularities involved.

6.13.4 - The following rules shall be applied in the cases where the analysis is performed by computer:

(a) Analysis report shall include three-dimensional illustrations of structural system by indicating the joint and element numbering.

(b) All input data as well as output data including internal forces and displacements shall be included in the analysis report in an easily understandable format.

(c) The title, author and the version of the computer software used in the analysis shall be clearly indicated.

(d) When requested by the approval authority, theory manual and user's guide of the computer software shall be included in the analysis report.

TABLE 6.8 - STRUCTURAL BEHAVIOUR FACTORS FOR NON-BUILDING STRUCTURES

<i>TYPE OF STRUCTURE</i>	R
Elevated liquid tanks, pressurised tanks, bunkers, vessels carried by frames of high ductility level or steel eccentric braced frames	4
Elevated liquid tanks, pressurised tanks, bunkers, vessels carried by frames of nominal ductility level or steel concentric braced frames	2
Cast-in-situ reinforced concrete silos and industrial chimneys with uniformly distributed mass along height ^(*)	3
Reinforced concrete cooling towers ^(*)	3
Space truss steel towers, steel silos and industrial chimneys with uniformly distributed mass along height ^(*)	4
Guyed steel high posts and guyed steel chimneys	2
Inverted pendulum type structures carried by a single structural element with mass concentrated at the top	2
Industrial type steel storage racks	4

^(*) Analysis of such structures shall be performed in accordance with 6.8 or 6.9 by considering sufficient number of discrete masses defined along the structure.

6.14. INSTALLATION OF STRONG MOTION RECORDERS

Upon endorsement by the Ministry of Public Works and Settlement, strong motion accelerographs shall be permitted to be installed by the ministry or university institutions on the public, private or corporate buildings and other structures for the purpose of recording the strong earthquake motions, and owners or operators of buildings or structures shall be responsible from the safety of such instruments.

CHAPTER 7 - EARTHQUAKE RESISTANT DESIGN REQUIREMENTS FOR REINFORCED CONCRETE BUILDINGS

7.0. NOTATION

Dimensioned expressions used in this chapter with the following notations are in *Newton* [N] for forces, *millimetre* [mm] for lengths and *MegaPascal* [MPa] = [N/mm²] for stresses.

A_c	= Gross section area of column or wall end zone
A_{ch}	= Gross section area of a solid wall, wall segment of a coupled wall, a floor or a floor segment of a perforated floor
A_{ck}	= Concrete core area within outer edges of confinement reinforcement
ΣA_e	= Effective shear area at any storey for the earthquake direction considered
ΣA_g	= Sum of section areas of structural elements at any storey behaving as structural walls in the direction parallel to the earthquake direction considered
ΣA_k	= Sum of masonry infill wall areas (excluding door and window openings) at any storey in the direction parallel to the earthquake direction considered
A_{os}	= Section area of spiral reinforcement
ΣA_p	= Sum of plan areas of all stories of building
A_{s1}	= Total area of tension reinforcement placed on one side of the beam-column joint at the top to resist the negative beam moment
A_{s2}	= Total area of tension reinforcement placed on the other side of the beam-column joint with respect to A_{s1} at the bottom to resist negative beam moment
A_{sd}	= Total reinforcement area of each of the cross rebar bundles in coupling beam
A_{sh}	= Along the height corresponding to transverse reinforcement spacing s , sum of projections of cross section areas of all legs of hoops and crossties of columns or wall end zones in the direction perpendicular to b_k considered
A_w	= Effective web area of column cross section (excluding protrusions in the direction perpendicular to the earthquake direction)
ΣA_w	= Sum of effective web areas of column cross sections, A_w 's at any storey
a	= Lateral distance between legs of hoops and/or crossties of columns or wall end regions
b_j	= Twice the smaller of the distances measured from the vertical centreline of a beam framing into the beam-column joint in the earthquake direction, to the edges of column (It shall not exceed beam width plus joint depth)
b_k	= For each of the orthogonal lateral directions, cross section dimension of concrete core of column or wall end zone (distance between the centres or outermost rebars)
b_w	= Width of beam web, thickness of wall web
D	= Concrete core diameter of circular column (distance between the centres of spiral reinforcement)
d	= Effective beam height
f_{cd}	= Design compressive strength of concrete
f_{ck}	= Characteristic compressive cylinder strength of concrete
f_{ctd}	= Design tensile strength of concrete
f_{yd}	= Design yield strength of longitudinal reinforcement
f_{yk}	= Characteristic yield strength of longitudinal reinforcement
f_{ywk}	= Characteristic yield strength of transverse reinforcement
H_{cr}	= Critical wall height
H_w	= Total wall height measured from top foundation level or ground floor level
h	= Column cross section dimension in the earthquake direction considered
h_k	= Beam height

ℓ_b	= Development length of tensile reinforcement as given in TS-500
ℓ_n	= Clear height of column between beams, clear span of beam between column or wall faces
ℓ_w	= Length of wall or segment of coupled wall in plan
M_a	= Moment at the bottom of column clear height which is used for the calculation of column shear force
M_{pa}	= Ultimate moment capacity calculated at the bottom of column clear height by considering f_{ck} , f_{yk} and strain hardening of steel
M_{pi}	= Positive or negative ultimate moment capacity calculated at column face on left end i of a beam by considering f_{ck} , f_{yk} and strain hardening of steel
M_{pj}	= Negative or positive ultimate moment capacity calculated at column face on right end j of a beam by considering f_{ck} , f_{yk} and strain hardening of steel
$\sum M_p$	= Sum of ultimate moment capacities of beams framing into a joint
$M_{pü}$	= Ultimate moment capacity calculated at the top of column clear height by considering f_{ck} , f_{yk} and strain hardening of steel
M_{ra}	= Ultimate moment resistance calculated at the bottom of column or wall clear height by considering f_{cd} and f_{yd}
M_{ri}	= Positive or negative ultimate moment resistance calculated at column or wall face on left end i of a beam by considering f_{cd} and f_{yd}
M_{rj}	= Negative or positive ultimate moment resistance calculated at column or wall face on right end j of a beam by considering f_{cd} and f_{yd}
$M_{rü}$	= Ultimate moment resistance calculated at the top of column or wall clear height by considering f_{cd} and f_{yd}
$M_{ü}$	= Moment at the top of column clear height which is used for the calculation of column shear force
N_d	= Factored axial force calculated under simultaneous action of vertical loads and seismic loads
N_{dmax}	= Greater of the factored axial forces calculated under vertical loads only and under simultaneous action of vertical and seismic loads
s	= Spacing of transverse reinforcement
V_c	= Contribution of concrete to shear strength
V_d	= Factored shear force calculated under simultaneous action of vertical loads and seismic loads
V_{dy}	= Simple beam-shear developed at the column face due to vertical loads
V_e	= Shear force taken into account for the calculation of transverse reinforcement of column or beam
V_{ik}	= Sum of shear forces calculated in the earthquake direction considered in accordance with Chapter 6 at all columns of the i'th storey
V_{is}	= Sum of shear forces calculated in the earthquake direction considered in accordance with Chapter 6 at the i'th storey columns where Eq.(7.3) is satisfied at both bottom and top joints
V_{kol}	= Smaller of the shear forces at above and below the joint calculated in accordance with Chapter 6
V_r	= Shear strength of a cross section of column, beam or wall
V_t	= Total seismic load acting on a building (base shear) according to Chapter 6
α_i	= Ratio of V_{is} / V_{ik} calculated for any i'th storey
\emptyset	= Rebar diameter
γ	= Angle of cross rebar bundle used in coupling beam with the horizontal axis
$\rho_{ü}$	= Tension reinforcement ratio of the top reinforcement at beam support section
ρ_s	= Volumetric ratio of spiral reinforcement of column [$\rho_s = 4 A_{os} / (D s)$]
ρ_{sh}	= Ratio of horizontal web reinforcement of wall to the gross area of wall web [$(\rho_{sh})_{min} = 0.0025$]

7.1. SCOPE

7.1.1 - Dimensioning and reinforcing of all structural elements of reinforced concrete buildings to be built in seismic zones shall be performed, along with currently enforced relevant standards and codes, primarily in accordance with the requirements of this chapter. Requirements for reinforced concrete building foundations are given in **Chapter 12**.

7.1.2 - Requirements and rules specified in this chapter are applicable to cast-in-situ monolithic reinforced concrete buildings, and unless otherwise stated, prefabricated buildings whose structural systems are comprised of reinforced and/or prestressed concrete elements.

7.1.3 - Lateral load carrying systems of reinforced concrete buildings covered in this chapter may be comprised of frames only, of walls only or of combination of frames and walls.

7.1.4 - Reinforced concrete buildings with concrete strength exceeding that of **C50 (BS 50)** and buildings where steel profiles are used as reinforcement in structural elements are outside the scope of this chapter.

7.2. GENERAL RULES

7.2.1. Classification of Reinforced Concrete Structural Systems

Lateral load resisting structural systems of reinforced concrete buildings shall be classified with respect to their seismic behaviour into two classes defined below. Special cases and requirements regarding the mixed use of such classes of systems are given in **6.5.4** of **Chapter 6**.

7.2.1.1 - Reinforced concrete structural systems given below are defined as *Systems of High Ductility Level*:

(a) Frame type structural systems comprised of columns and beams dimensioned and reinforced in accordance with the requirements of **7.3**, **7.4** and **7.5**.

(b) Structural systems comprised of solid or coupled structural walls dimensioned and reinforced in accordance with the requirements of **7.6**.

(c) Frame-wall structural systems made of combining the two systems defined above.

7.2.1.2 - Reinforced concrete structural systems given below are defined as *Systems of Nominal Ductility Level*:

(a) Frame type structural systems comprised of columns and beams dimensioned and reinforced in accordance with the requirements of **7.7**, **7.8** and **7.9**.

(b) Structural systems comprised of solid or coupled structural walls dimensioned and reinforced in accordance with the requirements of **7.10**.

(c) Frame-wall structural systems made of combining the two systems defined above.

7.2.2. Relevant Standards

Cast-in-situ and prefabricated reinforced concrete structural systems shall be designed, along with the requirements of this chapter, according to the seismic loads and analysis requirements given in **Chapter 6**, to other loads specified in TS-498 and TS-9967; and to the requirements as well as material and load factors specified in TS-500, TS-708, TS-3233 and TS-9967.

7.2.3. Section Stiffnesses to be Used in Structural Analysis

Section stiffnesses for uncracked sections shall be used in the structural analysis to be performed with the methods given in **Chapter 6**. However respective values for cracked sections may be used for beams framing into walls in their own plane and for coupling beams of the coupled structural walls.

7.2.4. Method to be Used in Section Design

The use of the *Ultimate Strength Method* given in TS-500 is mandatory in earthquake resistant dimensioning and reinforcement calculations of reinforced concrete structural elements in all seismic zones.

7.2.5. Material Strengths

7.2.5.1 - In all buildings to be built in seismic zones, concrete with strength less than that of **C16 (BS 16)** shall not be used. However it is mandatory to use **C20 (BS 20)** quality or higher strength concrete in below defined buildings to be built in the first and second seismic zones.

(a) Buildings with structural systems comprised only of frames of *high ductility level*,

(b) Irrespective of the structural system, all buildings with Building Importance Factor of **I=1.5** and **I=1.4** according to **Table 6.3** of **Chapter 6**.

7.2.5.2 - In all seismic zones, concrete shall not be produced without *concrete quality control requirements* specified in TS-500 and it shall not be placed without using vibrators.

7.2.5.3 - With the exception of elements mentioned in **7.2.5.4** below, reinforcing steel with strength exceeding that of **S420** shall not be used reinforced concrete structural elements. The rupture strain of reinforcement to be used shall not be less than 10%. Experimentally obtained average yield strength of reinforcing steel shall not be more than 1.3 times the characteristic yield strength specified in the relevant steel standard. In addition, experimentally obtained average rupture strength shall not be less than 1.25 times the average yield strength obtained as well from the experiment.

7.2.5.4 - Reinforcing steel with strength exceeding that of **S420** may be used in flat slabs, in the slabs of joist floors, in peripheral external walls of basements, in the webs of structural walls of buildings in which entire seismic loads are resisted by such walls of full building height satisfying both of the conditions given by **Eq.(7.14)** in **7.6.1.2**, and as prestressing steel in prefabricated buildings.

7.2.6. Development Length of Tensile Reinforcement

Unless stated otherwise in this chapter, development lengths of tensile rebars with and without hooks shall be determined in accordance with TS-500. However, in the case of 90 degree hooks, straight part at the end of the hook shall not be less than 12ϕ .

7.2.7. Welded Splices and Mechanically Connected Reinforcement

7.2.7.1 - Welded lap splices of longitudinal reinforcement shall be made by certified welders. Butt weld splices shall not be permitted.

7.2.7.2 - Tension test shall be applied to at least 2% of welded splices and mechanical connections of longitudinal reinforcement provided that number of tests shall not be less than 5. Experimentally determined tensile strength of the splice or connection shall not be less than that of the rebars spliced or connected.

7.2.7.3 - Transverse reinforcement shall not be permitted to be welded to longitudinal reinforcement.

7.2.7.4 - Frames of steel windows and doors, anchors, connection plates, elements of plumbing system, machinery and equipment shall not be permitted to be welded to longitudinal and transverse reinforcement.

7.2.8. Special Seismic Hoops and Crossties

Hoops and crossties used in columns, beam-column joints, wall end zones and beam confinement zones of all reinforced concrete systems of high ductility level or nominal ductility level in all seismic zones shall be *special seismic hoops* and *special seismic crossties* for which requirements are given below (Fig.7.1):

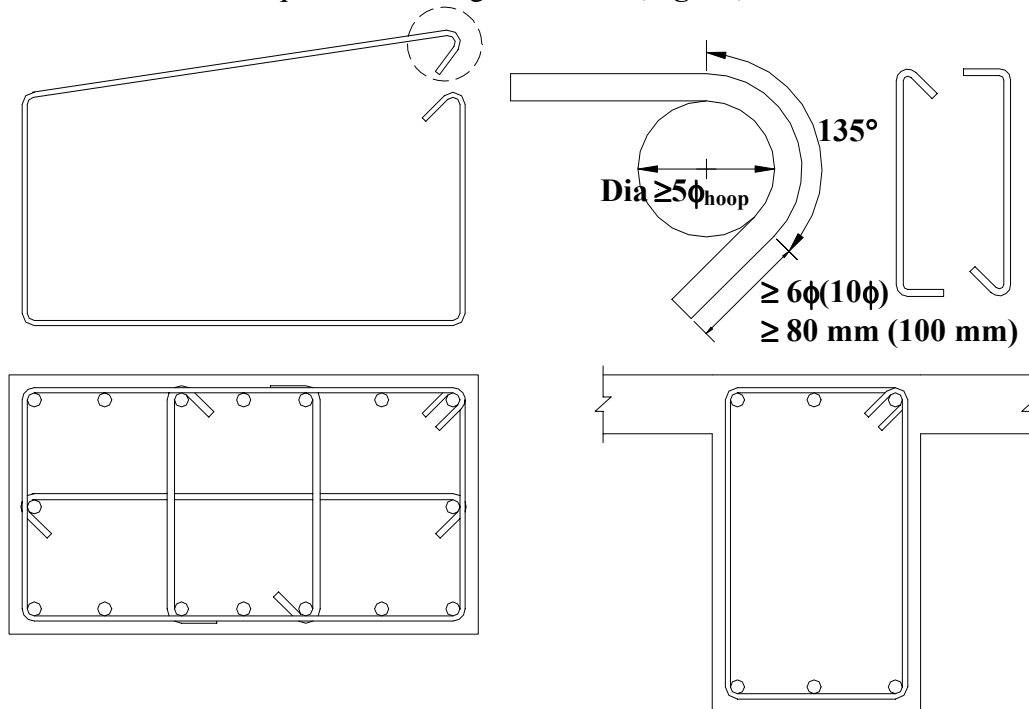

Figure 7.1

7.2.8.1 - Special seismic hoops shall always have *135 degree hooks* at both ends. However, 90 degree hook may be made at one end of the special seismic crossties. In this case, crossties with 135 degree and 90 degree hooks shall be placed on one face of a column or wall in a staggered form in both horizontal and vertical directions. 135 degree hooks shall be bent around a circle with at least $5\varnothing$ diameter where \varnothing denotes the diameter of transverse reinforcing bar. Lengths of hooks measured from tangent point shall not be less than $10\varnothing$ and 100 mm for plain bars, $6\varnothing$ and 80 mm for ribbed bars.

7.2.8.2 - Special seismic hoops shall engage the longitudinal reinforcement from outside with hooks closed around the same rebar. Diameter and spacing of special seismic crossties shall be the same as those of hoops. Crossties shall be connected to longitudinal reinforcement always at both ends. Hoops and crossties shall be firmly tied such that they shall not move during concrete pouring.

7.3. COLUMNS OF HIGH DUCTILITY LEVEL

7.3.1. Cross-section Requirements

7.3.1.1 - Shorter dimension of columns with rectangular section shall not be less than 250 mm and section area shall not be less than 75000 mm^2 . Diameter of circular columns shall be at least 300 mm.

7.3.1.2 - Gross section area of column shall satisfy the condition $A_c \geq N_{dmax} / (0.50 f_{ck})$.

7.3.2. Longitudinal Reinforcement Requirements

7.3.2.1 - Longitudinal column reinforcement shall not be less than 1%, nor shall it be more than 4% of gross section area. Minimum number of rebars shall be $4\varnothing16$ or $6\varnothing14$ for rectangular columns and $6\varnothing14$ for circular columns.

7.3.2.2 - Longitudinal reinforcement ratio shall not exceed 6% at lap spliced sections.

7.3.3. Arrangement of Longitudinal Reinforcement

7.3.3.1 - Lap splices of column longitudinal reinforcement should be made, as much as possible, within the column central zone defined in **7.3.4.2**. In this case the splice length shall be equal to the development length l_b given in TS-500 for tension bars.

7.3.3.2 - In the case where lap splices of column longitudinal reinforcement are made at the bottom end of the column, the following requirements shall be met:

(a) In the case where 50% of longitudinal reinforcement or less is spliced at the bottom end of column, lap splice length shall be at least 1.25 times l_b .

(b) In the case where more than 50% of longitudinal reinforcement is spliced at the bottom end of column, lap splice length shall be at least 1.5 times l_b . The same condition shall apply to starter bars protruding from the foundation.

(c) In both cases given above, minimum transverse reinforcement defined in **7.3.4.1** shall be used along the length of the lap splice.

7.3.3.3 - In the case where the column cross-section changes between consecutive stories, slope of the longitudinal reinforcement within the beam-column joint shall not be more than 1/6 with respect to the vertical. When the change in cross section is more or in the case of top storey columns; development length of the column longitudinal reinforcement within the other side of the beam above shall not be less than 1.5 times the development length ℓ_b given in TS-500 for tension reinforcement, nor shall it be less than 40ϕ . In the case of no beam present on the other side, development shall be achieved, if necessary, by downward bending of rebar along the far face of the column. Length of 90 degree bent horizontal hook or downward bent vertical hook shall be at least 12ϕ (Fig. 7.2).

7.3.3.4 - Longitudinal distance between mechanical or welded connections on adjacent longitudinal rebars shall not be less than 600 mm.

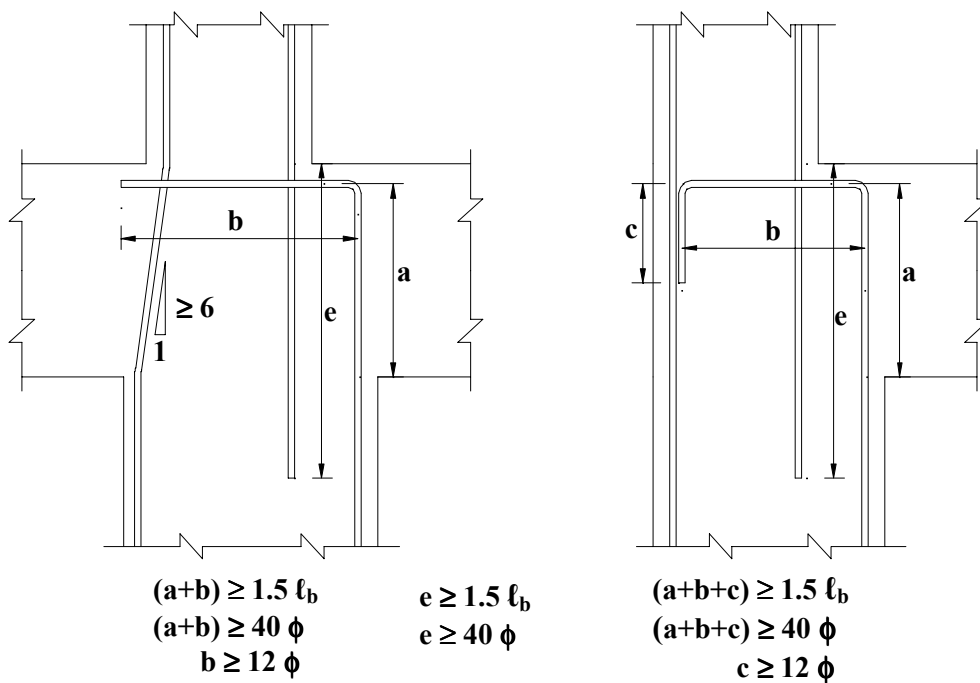

Figure 7.2

7.3.4. Transverse Reinforcement Requirements

Unless a more unfavourable situation governs in accordance with below given 7.3.7.6, the minimum transverse reinforcement requirements of columns are those specified in 7.3.4.1 for *column confinement zones* and in 7.3.4.2 for the *column central zone* (Fig. 7.3). *Special seismic hoops* and *special seismic crossties* defined in 7.2.8 shall be used along the full length of the column.

7.3.4.1 - *Special confinement zones* shall be arranged at the bottom and top ends of each column. Length of each of the confinement zones shall not be less than smaller of column cross section dimensions (diameter in circular columns), 1/6 the clear height of column (measured upward from floor level or downward from the bottom face of the deepest beam framing into the column), and 500 mm. Requirements for transverse reinforcement to be used in confinement zones are given below. Such reinforcement

shall be extended into the foundation for a length equal to at least twice the smaller of column cross section dimensions.

(a) Transverse reinforcement with a diameter less than $\varnothing 8$ shall not be used in confinement zones. Along the column, spacing of hoops and crossties shall not be more than $1/3$ the smaller cross section dimension and 100 mm, nor shall it be less than 50 mm. Lateral distance between legs of hoops and crossties, a , shall not be more than 25 times the hoop diameter. Pitch of the continuous spirals shall not be more than $1/5$ the core diameter and 80 mm.

(b) In the case where $N_d > 0.20 A_c f_{ck}$ in columns with hoops, minimum total area of transverse reinforcement to be used in confinement zones shall be calculated to satisfy the more unfavourable of the requirements given in Eq.(7.1). In this calculation, core diameter of column, b_k , shall be considered separately for each direction (Fig. 7.3).

$$A_{sh} \geq 0.30 s b_k [(A_c / A_{ck}) - 1] (f_{ck} / f_{ywk}) \quad (7.1a)$$

$$A_{sh} \geq 0.075 s b_k (f_{ck} / f_{ywk}) \quad (7.1b)$$

(c) In the case where $N_d > 0.20 A_c f_{ck}$ in columns with spirals, minimum volumetric ratio of transverse reinforcement to be used in confinement zones shall be calculated to satisfy the more unfavourable of the requirements given in Eq.(7.2).

$$\rho_s \geq 0.45 [(A_c / A_{ck}) - 1] (f_{ck} / f_{ywk}) \quad (7.2a)$$

$$\rho_s \geq 0.12 (f_{ck} / f_{ywk}) \quad (7.2b)$$

(d) In the case where $N_d \leq 0.20 A_c f_{ck}$, at least $2/3$ the transverse reinforcement given by Eq.(7.1) and Eq.(7.2) shall be used as a minimum transverse reinforcement in column confinement zones.

7.3.4.2 - *Column central zone* is the region between the confinement zones defined at the bottom and top ends of the column (Fig. 7.3).

Transverse reinforcement with a diameter less than $\varnothing 8$ shall not be used along the column central zone. Along this zone, spacing of hoops and crossties shall not be more than half the smaller cross section dimension and 200 mm. Lateral distance between the legs of hoops and crossties, a , shall not be more than 25 times the hoop diameter.

7.3.4.3 - In the following cases, transverse reinforcement provided in confinement zones shall also be extended into column central zone.

(a) All columns at the storey where *Strength Irregularity Factor* defined for type **B1** irregularity in Table 6.1 of Chapter 6 varies between **0.60** and **0.80**.

(b) Columns supporting upper storey walls in the case of type **B3** irregularity defined in Table 6.1 of Chapter 6 (Transverse reinforcement shall also be provided along the development length of column reinforcement extended into the wall).

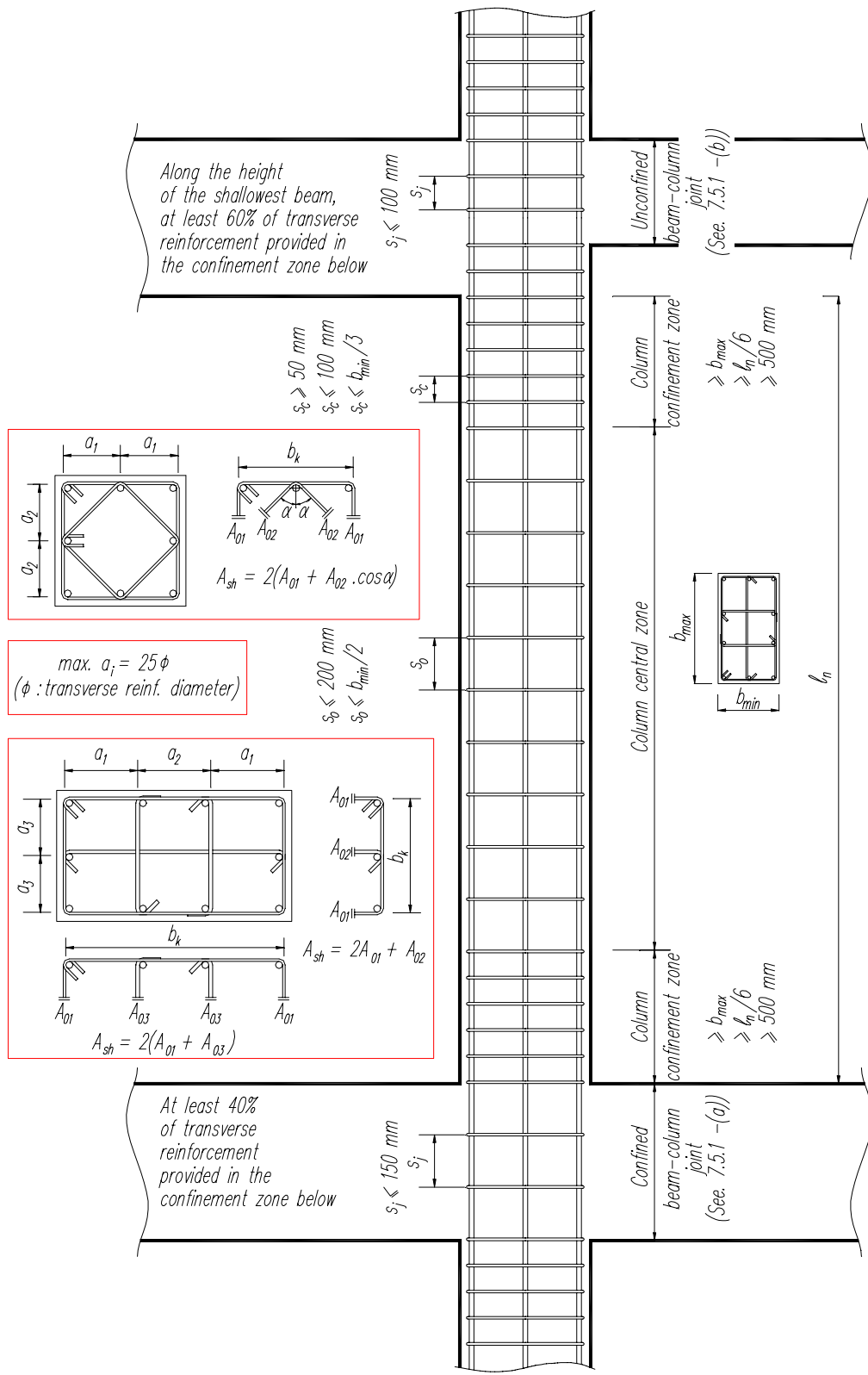

Figure 7.3

7.3.5. Requirement of Having Columns Stronger Than Beams

7.3.5.1 - In structural systems comprised of frames only or of combination of frames and walls, sum of ultimate moment resistances of columns framing into a beam-column joint shall be at least 20% more than the sum of ultimate moment resistances of beams framing into the same joint (**Fig. 7.4**):

$$(M_{ra} + M_{r\ddot{u}}) \geq 1.2 (M_{ri} + M_{rj}) \quad (7.3)$$

7.3.5.2 - In order that **Eq.(7.3)** is applied, beams framing into the joint shall satisfy the dimensional requirements given in 7.4.1.1.

7.3.5.3 - **Eq.(7.3)** shall be applied separately for both earthquake directions and senses to yield the most unfavourable result (**Fig. 7.4**). In calculating the column ultimate moment resistances, axial forces N_d shall be taken to yield the minimum moments consistent with the sense of earthquake direction.

7.3.5.4 – Special situations regarding the application of **Eq.(7.3)** are described in the following:

- (a) **Eq.(7.3)** need not to be applied in the case where $N_d \leq 0.10 A_c f_{ck}$ in both columns framing into the joint.
- (b) **Eq.(7.3)** need not to be checked in single storey buildings and in joints of topmost storey of multi-storey buildings.
- (b) **Eq.(7.3)** need not to be checked in the case where a wall connected by beams works like a column in its weak direction.

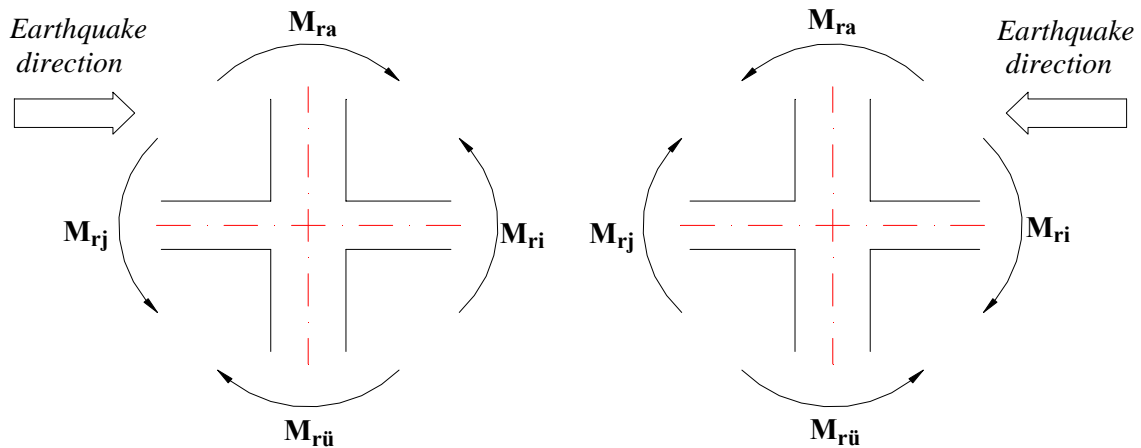

Figure 7.4

7.3.6. The Case Where Some Columns Cannot Satisfy the Requirement of Having Columns Stronger Than Beams

7.3.6.1 – In structural systems comprised of frames only or of combination of walls and frames, **Eq.(7.3)** may be permitted not to be satisfied in a given earthquake direction at some joints at the bottom and/or top of an i 'th storey, provided that **Eq.(7.4)** given below is satisfied.

$$\alpha_i = V_{is} / V_{ik} \geq 0.70 \quad (7.4)$$

Columns satisfying the condition of $N_d \leq 0.10 A_c f_{ck}$ may be taken into account in the calculation of V_{is} even if they do not satisfy Eq.(7.3).

7.3.6.2 – In the case where Eq.(7.4) is satisfied, bending moments and shear forces of columns satisfying Eq.(7.3) at both bottom and top joints shall be amplified by multiplying with the ratio $(1/\alpha_i)$ within the range of $0.70 < \alpha_i < 1.00$.

7.3.6.3 – In the case where Eq.(7.4) is not satisfied at any storey, all frames of structural systems which may be comprised of frames only or of combination of walls and frames shall be considered as *frames of nominal ductility level*, and the analysis shall be repeated by changing the Structural Behaviour Factor according to **Table 6.5**. As it is mentioned in **6.5.4.2** in **Chapter 6**, it is possible, however, to combine frames of nominal ductility level with structural walls of high ductility level.

7.3.7. Shear Safety of Columns

7.3.7.1 – Shear force, V_e , to be taken into account for the design of column transverse reinforcement shall be calculated by Eq.(7.5).

$$V_e = (M_a + M_{\bar{u}}) / \ell_n \quad (7.5)$$

In determining M_a and $M_{\bar{u}}$ of Eq.(7.5), below given **7.3.7.2** shall be applied for the case where Eq.(7.3) is satisfied at both bottom and top joints of the column, whereas **7.3.7.3** shall be applied otherwise (**Fig.7.5**).

7.3.7.2 – Sum of ultimate moment capacities, $\sum M_p$, at the ends of beams framing into the joint where Eq.(7.3) is satisfied shall be calculated:

$$\sum M_p = M_{pi} + M_{pj} \quad (7.6)$$

In the case where a more rigorous analysis is not performed, it may be assumed to be $M_{pi} \cong 1.4 M_{ri}$ and $M_{pj} \cong 1.4 M_{rj}$. The moment $\sum M_p$ shall be distributed to columns in proportion to the moments obtained in accordance with **Chapter 6** at column ends framing into the joint, and such distributed moments obtained at the bottom or top end of the column shall be considered in Eq.(7.5) as M_a or $M_{\bar{u}}$, respectively. Eq.(7.6) shall be applied separately for both senses of earthquake direction and the largest value of $\sum M_p$ shall be considered in the distribution.

Even if Eq.(7.3) is satisfied, calculation of M_a and $M_{\bar{u}}$ of Eq.(7.5) may be performed conservatively in accordance with below given **7.3.7.3**.

7.3.7.3 – End moments of columns framing into the joint where Eq.(7.3) is not satisfied shall be calculated as the ultimate moment capacities and shall be substituted into Eq.(7.5) as M_a and/or $M_{\bar{u}}$. In the case where a more rigorous analysis is not performed, it may be assumed to be $M_{pa} \cong 1.4 M_{ra}$ and $M_{p\bar{u}} \cong 1.4 M_{r\bar{u}}$. In the calculation of moments M_{pa} and $M_{p\bar{u}}$, axial force N_d shall be taken into account so as to maximise those moments, being consistent with the sense of earthquake direction.

7.3.7.4 – The moment M_a at the bottom of a column framing into the foundation shall also be calculated as the ultimate moment capacity in accordance with **7.3.7.3**.

7.3.7.5 – Shear force, V_e , obtained according to **Eq.(7.5)**, shall not be less than the shear force calculated under factored gravity and seismic loads combined, and in addition it shall satisfy the conditions given by **Eq.(7.7)** below. In the case where the condition given by **Eq.(7.7b)** is not satisfied, cross section dimensions shall be increased as required and the seismic analysis shall be repeated.

$$V_e \leq V_r \quad (7.7a)$$

$$V_e \leq 0.22 A_w f_{cd} \quad (7.7b)$$

Storey No.	Calculation of $M_{\bar{u}}$		Calculation of M_a	
	Eq.7.3 is satisfied at column top end	Eq.7.3 is not satisfied at column top end	Eq.7.3 is not satisfied at column bottom end	Eq.7.3 is satisfied at column bottom end
$i+1$				
i				
$i-1$				
	$\Sigma M_p = M_{pi} + M_{pj}$ $M_{\bar{u}} = \frac{M_{h\bar{u}(i)}}{M_{h\bar{u}(i)} + M_{ha(i+1)}} \Sigma M_p$		$\Sigma M_p = M_{pi} + M_{pj}$ $M_a = \frac{M_{ha(i)}}{M_{ha(i)} + M_{h\bar{u}(i-1)}} \Sigma M_p$	
<p>$M_{h\bar{u}(i)}$: Moment obtained at top end of i' th storey column according to Chapter 6 $M_{ha(i)}$: Moment obtained at bottom end of i' th storey column according to Chapter 6</p>				

Figure 7.5

7.3.7.6 – In calculating the column transverse reinforcement for shear force, V_e , contribution of concrete to the shear strength of the section, V_c , shall be determined in accordance with TS-500. However it shall be taken $V_c = 0$ in calculating the transverse reinforcement along the column confinement zones defined in **7.3.4.1** when $V_e \geq 0.5V_d$ and at the same time $N_d \leq 0.05 A_c f_{ck}$.

7.3.8. Conditions Related to Short Columns

Short columns may be developed due to structural arrangements or due to openings provided in infill walls between columns (**Fig. 7.6**). In cases where short columns cannot be avoided, shear force for transverse reinforcement shall be calculated by

Eq.(7.5). The moments in **Eq.(7.5)** shall be calculated at bottom and top ends of the short column as $M_a \cong 1.4 M_{ra}$ and $M_{\ddot{u}} \cong 1.4 M_{r\ddot{u}}$ with ℓ_n being the length of the short column. In addition, calculated shear force shall satisfy the conditions given by **Eq.(7.7)**. The minimum transverse reinforcement requirements and conditions of arrangement defined in **7.3.4.1** for column confinement zones shall be applied along the length of the short column. Transverse reinforcement shall be extended along the full storey length of columns which are transformed into short columns in between infill walls (**Fig. 7.6**).

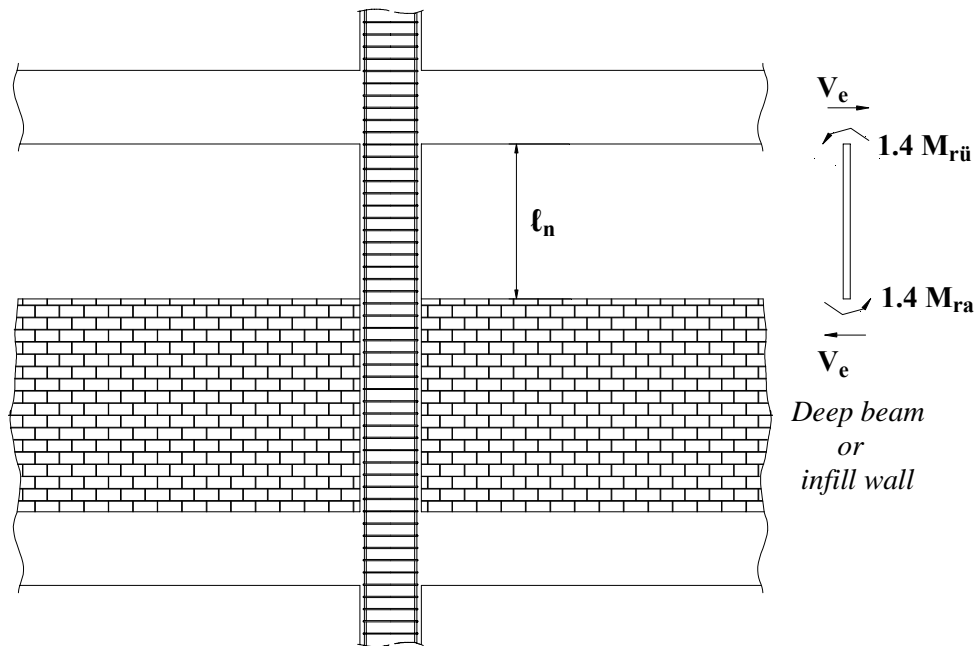

Figure 7.6

7.4. BEAMS OF HIGH DUCTILITY LEVEL

7.4.1. Cross-section Requirements

7.4.1.1 – Dimensional requirements of cross-section of beams forming frames together with columns, or of beams connected to structural walls in their own planes are given below:

- (a) Width of the beam web shall be at least 250 mm. Web width shall not exceed the sum of the beam height and the width of the supporting column in the perpendicular direction to the beam axis.
- (b) Beam height shall not be less than 3 times the thickness of floor slab and 300 mm, nor shall it more than 3.5 times the beam web width (*).
- (c) Beam height should not be more than 1/4 the clear span. Otherwise below given **7.4.2.5** shall be applied (*).

(*). Amended on July 2, 1998. Official Gazette No.23390.

(d) Limitations specified above in relation to beam width and height are not applicable to reinforced concrete or prestressed/prefabricated beams with hinge connections to columns, to coupling beams of coupled structural walls, and to the secondary beams which are connected to frame beams outside the beam-column joints.

7.4.1.2 - It is essential that design axial force satisfies the condition $N_d \leq 0.1 A_c f_{ck}$ in order that any structural element be sized and reinforced as a beam. Otherwise such elements shall be sized and reinforced as a column in accordance with 7.3.

7.4.2. Longitudinal Reinforcement Requirements

7.4.2.1 – The requirement given by Eq.(7.8) shall be applied as the minimum ratio of top tension reinforcement at beams supports.

$$\rho_{ti} \geq f_{ctd} / f_{yd} \quad (7.8)$$

7.4.2.2 – Diameter of longitudinal rebars shall not be less than 12 mm. At least two rebars each at the bottom and top of the beam shall be continuously provided along the full span length of the beam.

7.4.2.3 – In the first and second seismic zones, bottom reinforcement at a beam support shall not be less than 50% of the top reinforcement provided at the same support. However this percentage may be decreased to 30% in the third and fourth seismic zones.

7.4.2.4 – Ratio of tensile reinforcement along beam spans and at supports shall not be more than the maximum value specified in TS-500 and 2%.

7.4.2.5 (*) – In the special cases where the condition given in para. (c) of 7.4.1.1 is not satisfied, web reinforcement shall be provided along the beam height on both sides of the web. Total area of web reinforcement shall not be less than 30% of the greater of the sum of top and bottom longitudinal reinforcement at right or left support sections. Diameter of web reinforcement shall not be less than 12 mm and spacing shall not be more than 300 mm. For the development of web reinforcement similar to that of longitudinal reinforcement, para. (b), (c) and (d) of 7.4.3.1 shall be applied.

7.4.3. Arrangement of Longitudinal Reinforcement

7.4.3.1 – Requirements for the placement and development of the longitudinal reinforcement are given below (Fig. 7.7):

(a) At least 1/4 the maximum of the top support reinforcement at the ends of a beam shall be extended continuously along the full span length. The remaining part of the top support reinforcement shall be arranged in accordance with TS-500.

(b) In cases where beams framing into columns are not extended to the other side of columns, bottom and top beam reinforcement shall be extended up to the face of the

(*) Amended on July 2, 1998. Official Gazette No.23390.

other side of the confined core of the column and then shall be bent 90 degrees from inside the hoops. In this case, total length of the horizontal part of the longitudinal rebar inside the column and the 90 degree bent vertical part shall not be less than the straight development length specified in TS-500. Horizontal part of the 90 degree bent shall not be less than $0.4l_b$ and vertical part shall not be less than 12ϕ .

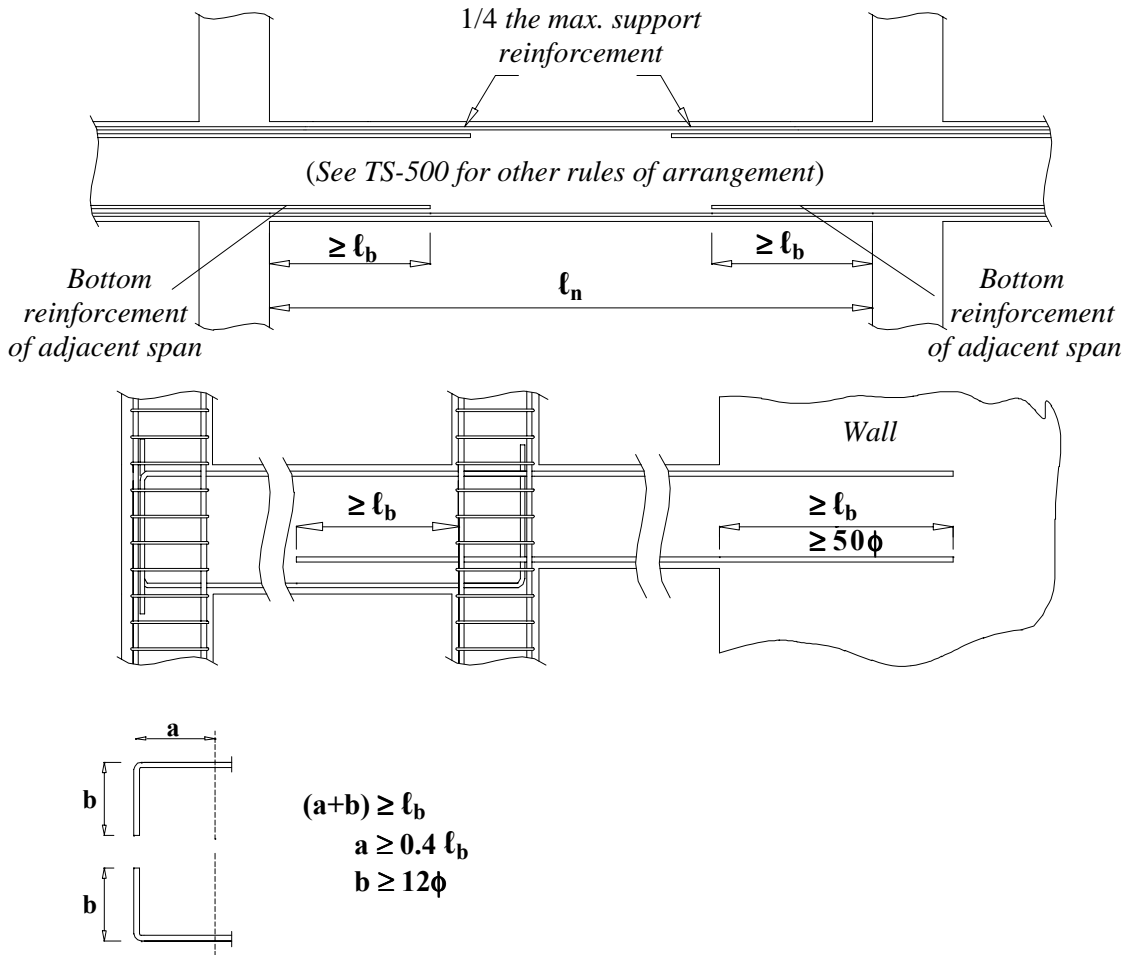

Figure 7.7

(c) In the case where beams frame into columns from both sides, beam bottom rebars shall be extended to the adjacent span from the column face by at least the development length l_b given in TS-500. In cases where this is not possible because of reasons such as the depth difference in beams, development shall be achieved in a way similar to para.(b) above, i.e., to the case where beam is not extended to the other side of the column.

(d) In case of beams connected to structural walls in their own planes, development of reinforcement may be achieved by straight bars without any bent. In such a case, development length of rebar inside the wall shall not be less than l_b and 50ϕ .

7.4.3.2 -Requirements related to splicing of longitudinal reinforcement are given below:

(a) Lap splicing shall not be made along beam confinement zones defined in 7.4.5.2 below, within beam-column joints, and in regions where reinforcement has a possibility of yielding, such as the mid-span region for bottom reinforcement. In places outside such regions where lap splicing can be made, *special seismic hoops* defined in 7.2.8 shall be used. Spacing of such hoops shall not exceed 1/4 the beam depth and 100 mm.

(b) Mechanical connections or welded lap splices shall only be applied to every alternate bar at a section and longitudinal distance between two consecutive splices (or connections) shall not be less than 600 mm.

7.4.4. Transverse Reinforcement Requirements

A region with a length twice the beam depth measured from the column face of a beam support shall be defined as *confinement zone* and *special seismic hoops* defined in 7.2.8 shall be used along this region. In the confinement zone, distance of the first hoop to the column face shall be max. 50 mm. Unless a more unfavourable value is obtained from 7.4.5.3, hoop spacing shall not exceed 1/4 the beam depth, 8 times the minimum diameter of the longitudinal reinforcement and 150 mm (Fig.7.8). Outside the confinement zone, minimum transverse reinforcement requirements specified in TS-500 shall be applied.

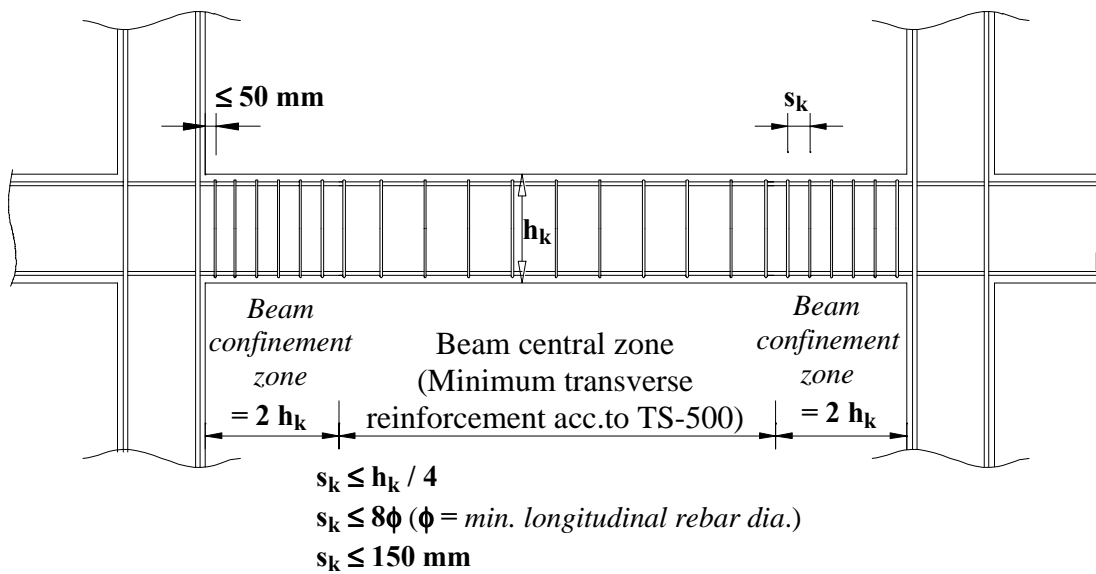

Figure 7.8

7.4.5. Shear Safety of Beams

7.4.5.1 - Shear force, V_e , to be taken into account for beam transverse reinforcement shall be calculated by Eq.(7.9) such that the most unfavourable result is obtained by separately considering the cases of earthquake acting from left to right or from right to left (Fig.7.9).

$$V_e = V_{dy} \pm (M_{pi} + M_{pj}) / \ell_n \quad (7.9)$$

Unless a more rigorous analysis is performed, ultimate moment capacities at the beam ends may be taken as $M_{pi} \cong 1.4 M_{ri}$ and $M_{pj} \cong 1.4 M_{rj}$.

7.4.5.2 – Shear force, V_e , calculated by Eq.(7.9) shall satisfy the conditions given below by Eq.(7.10). In the case where the condition given by Eq.(7.10b) is not satisfied, cross-section dimensions shall be increased as required and the seismic analysis shall be repeated.

$$V_e \leq V_r \quad (7.10a)$$

$$V_e \leq 0.22 b_w d f_{cd} \quad (7.10b)$$

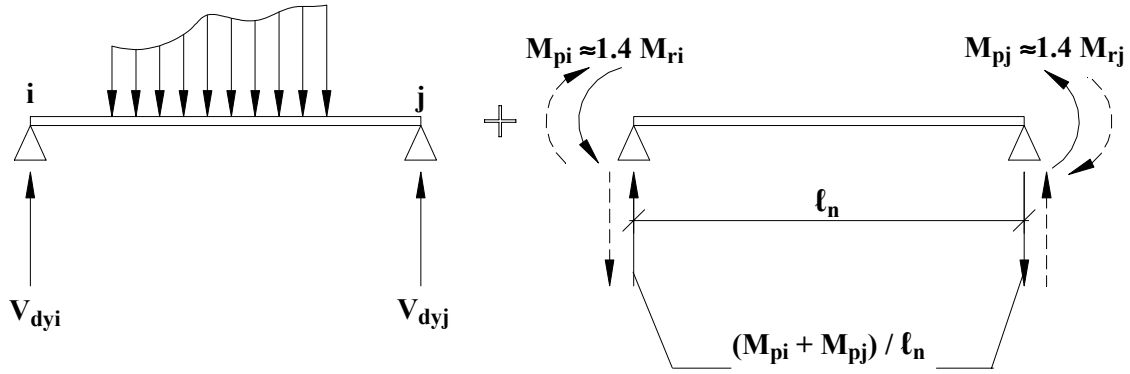

Figure 7.9

7.4.5.3 - In calculating the beam transverse reinforcement for shear force, V_e , contribution of concrete to the shear strength of the section, V_c , shall be determined in accordance with TS-500. However when $V_e - V_{dy} \geq 0.5V_d$ it shall be taken $V_c = 0$ in calculating the transverse reinforcement along the beam confinement zones defined in 7.4.4. In no case shall the contribution of inclined longitudinal bars to the shear strength be taken into account.

7.5. BEAM-COLUMN JOINTS OF FRAME SYSTEMS OF HIGH DUCTILITY LEVEL

7.5.1. Confined and Unconfined Joints

Beam-column joints of frame systems comprised of columns and beams of high ductility level shall be separated into two classes as defined below.

(a) In the case where beams frame into all four sides of a column and where the width of each beam is not less than 3/4 the adjoining column width, such a beam-column joint shall be defined as a *confined joint*.

(b) All joints not satisfying the above given conditions shall be defined as *unconfined joint*.

7.5.2. Shear Safety of Beam-Column Joints

7.5.2.1 – Shear force in beam-column joints along the earthquake direction considered (Fig.7.10) shall be calculated by Eq.(7.11).

$$V_e = 1.25 f_{yk} (A_{s1} + A_{s2}) - V_{kol} \quad (7.11)$$

In the case where beam frames into column from only one side and discontinuous on the other side, it shall be $A_{s2} = 0$.

7.5.2.2 – The shear force calculated by Eq.(7.11) in a joint along the given earthquake direction shall in no case exceed the limits given below (Fig.7.10) (*). In the cases where those limits are exceeded, cross-section dimensions of column and/or beam shall be increased and the seismic analysis shall be repeated.

(a) In confined joints: $V_e \leq 0.60 b_j h f_{cd}$ (7.12)

(b) In unconfined joints: $V_e \leq 0.45 b_j h f_{cd}$ (7.13)

7.5.2.3 – Requirements for minimum transverse reinforcement in beam-column joints are given below (Fig. 7.3):

(a) In confined joints, at least 40 % of the amount of transverse reinforcement existing in the confinement zone of the column below shall be provided along the height of the joint. However, diameter of transverse reinforcement shall not be less than 8 mm and its spacing shall not exceed 150 mm.

(b) In unconfined joints, at least 60 % of the amount of transverse reinforcement existing in the confinement zone of the column below shall be provided along the height of the joint. However in this case, diameter of transverse reinforcement shall not be less than 8 mm and its spacing shall not exceed 100 mm.

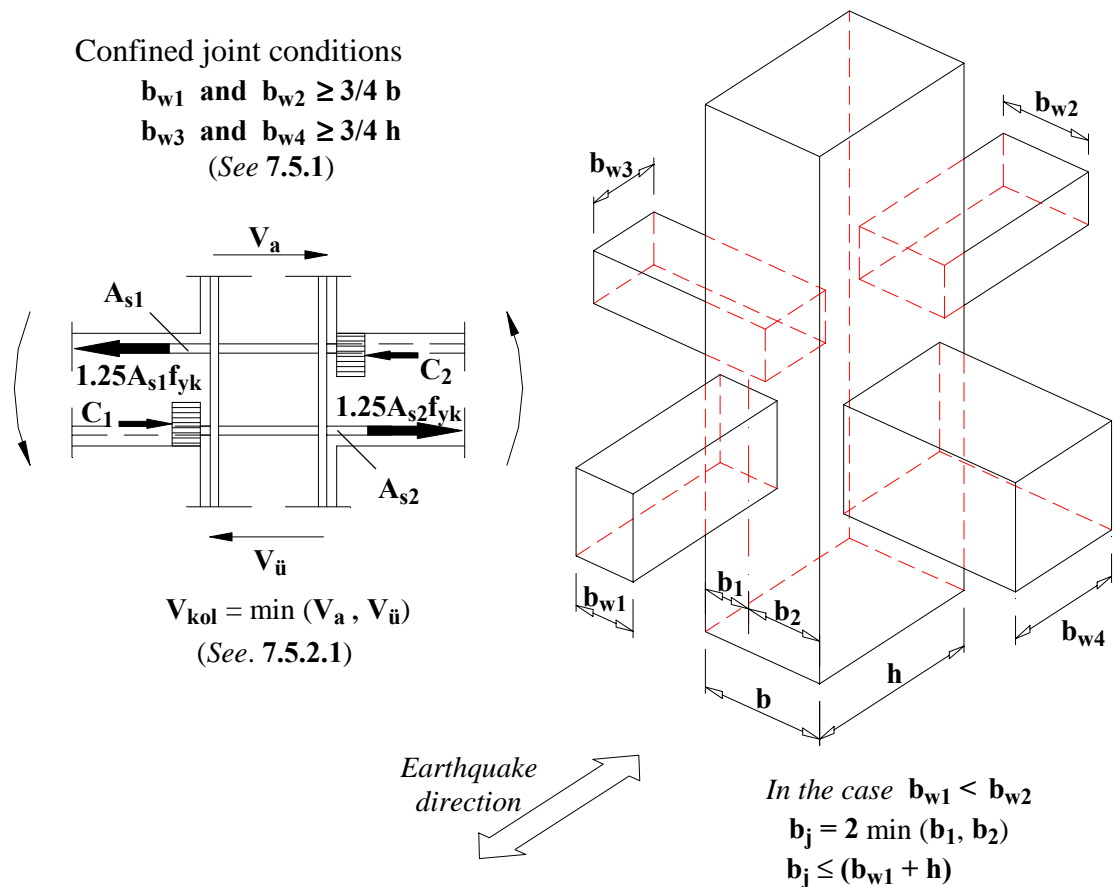

Figure 7.10

(*) Amended on July 2, 1998. Official Gazette No.23390.

7.6. STRUCTURAL WALLS OF HIGH DUCTILITY LEVEL

7.6.1. Cross-Section Requirements

7.6.1.1 – Structural walls are the vertical elements of the structural system where the ratio of length to thickness in plan is equal to at least seven. With the exception of the special case given in **7.6.1.2** below, wall thickness shall not be less than 1/15 the storey height and 200 mm. However in walls where $H_w / \ell_w > 2.0$, wall thickness shall not be less than 1/12 the storey height along the *critical wall height* defined in **7.6.2.2** below.

7.6.1.2 – In buildings where seismic loads are fully carried by structural walls along the full height of building, wall thickness shall not be less than 1/20 the highest storey height and 150 mm, provided that both of the conditions given by **Eq.(7.14)** are satisfied.

$$\Sigma A_g / \Sigma A_p \geq 0.002 \quad (7.14a)$$

$$V_t / \Sigma A_g \leq 0.5 f_{ctd} \quad (7.14b)$$

Eq.(7.14) shall be applied at the ground floor level in buildings with stiff peripheral walls in basement stories, whereas it shall be applied at foundation top level for other buildings.

7.6.2. Wall End Zones and Critical Wall Height

7.6.2.1 - *Wall end zones* shall be developed on both ends of walls where $H_w / \ell_w > 2.0$ (**Fig. 7.11**). Wall end zones may be developed within the wall itself or within an adjoining wall or in an enlarged section at the edge of the wall.

7.6.2.2 – The *critical wall height* measured from the foundation level shall be determined as to satisfy the unfavourable one of the following conditions provided that it does not exceed $2\ell_w$.

$$H_{cr} \geq \ell_w \quad (7.15a)$$

$$H_{cr} \geq H_w / 6 \quad (7.15b)$$

In buildings where the stiffnesses of reinforced concrete peripheral walls in basement stories are excessive compared to upper stories, and where basement slabs behave as rigid diaphragms in horizontal planes, H_w and H_{cr} shall be considered upwards from the ground floor. In such buildings critical wall height shall be extended downwards along the height of first basement storey below the ground floor.

7.6.2.3 – In structural walls with rectangular cross section, the plan length of each of the end zones along the above defined *critical wall height* shall not be less than 20% of the total plan length of the wall, nor shall it be two times the wall thickness. The plan length of each of the end zones along the wall section above the *critical wall height* shall not be less than 10% of the total plan length of the wall, nor shall it be less than the wall thickness (**Fig. 7.11**).

7.6.2.4 – In the case where wall end zones are arranged within an adjoining walls or at enlarged sections at the edges of the wall, cross section area of each of the wall end zones shall be equal at least to the area defined in **7.6.2.3**.

7.6.3. Web Reinforcement Requirements

7.6.3.1 – Total cross section area of each of the vertical and horizontal web reinforcement on both faces of structural wall shall not be less than 0.0025 of the gross section area of the *wall web* remaining in between the wall end zones. In the case where $H_w / \ell_w \leq 2.0$, wall web section shall be considered as the full section of the wall. The spacing of longitudinal and transverse reinforcement in wall web shall not be more than 250 mm (**Fig. 7.11**).

7.6.3.2 – In buildings where both conditions given by **Eq.(7.14)** of **7.6.1.2** above are satisfied, each of the total vertical and horizontal web reinforcement ratios may be decreased to 0.0015. However in such a case, reinforcement spacing shall not exceed 300 mm.

7.6.3.3 – Excluding the wall end zones, reinforcement mesh on both faces of the wall web shall be tied each other by at least 4 *special seismic crossties* per unit square meter of the wall surface. However, excluding the wall end zones, at least 10 special seismic crossties per unit square meter of the wall surface shall be used along the *critical wall height* defined in **7.6.2.2**. Crosstie diameter shall be at least equal to that of the horizontal reinforcement.

7.6.4. Arrangement of Web Reinforcement

Horizontal web reinforcement may be arranged as explained below in **7.6.4.1** or in **7.6.4.2** (**Fig. 7.11**). Horizontal web reinforcement so arranged may be taken into account in determining the confinement reinforcement to be provided in accordance with below given **7.6.5.2** at wall end zones along the *critical wall height*.

7.6.4.1 – Horizontal web rebars shall be bent 90 degree at the outer edge of the wall end zone and tied to the vertical corner reinforcement at the other face by a 135 degree hook.

7.6.4.2 – In the case where horizontal web rebars are terminated at the wall end without 90 degree bent, \supset shaped horizontal bars with the same diameter of web reinforcement shall be placed at both ends of the wall. Those bars shall be extended inside the wall web by at least the development length measured from the inner boundary of the wall end zone.

7.6.5. Reinforcement Requirements at Wall End Zones

7.6.5.1 – The ratio of the total area of vertical reinforcement at each wall end zone to the gross wall cross section area shall not be less than 0.001. However this ratio shall be increased to 0.002 along the *critical wall height* defined in **7.6.2.2**. Amount of vertical reinforcement at each wall end zone shall not be less than **4Ø14** (**Fig. 7.11**).

7.6.5.2 – Vertical reinforcement at wall end zones shall be confined as similar to columns, by transverse reinforcement made of hoops and crossties, in accordance with the below given rules.

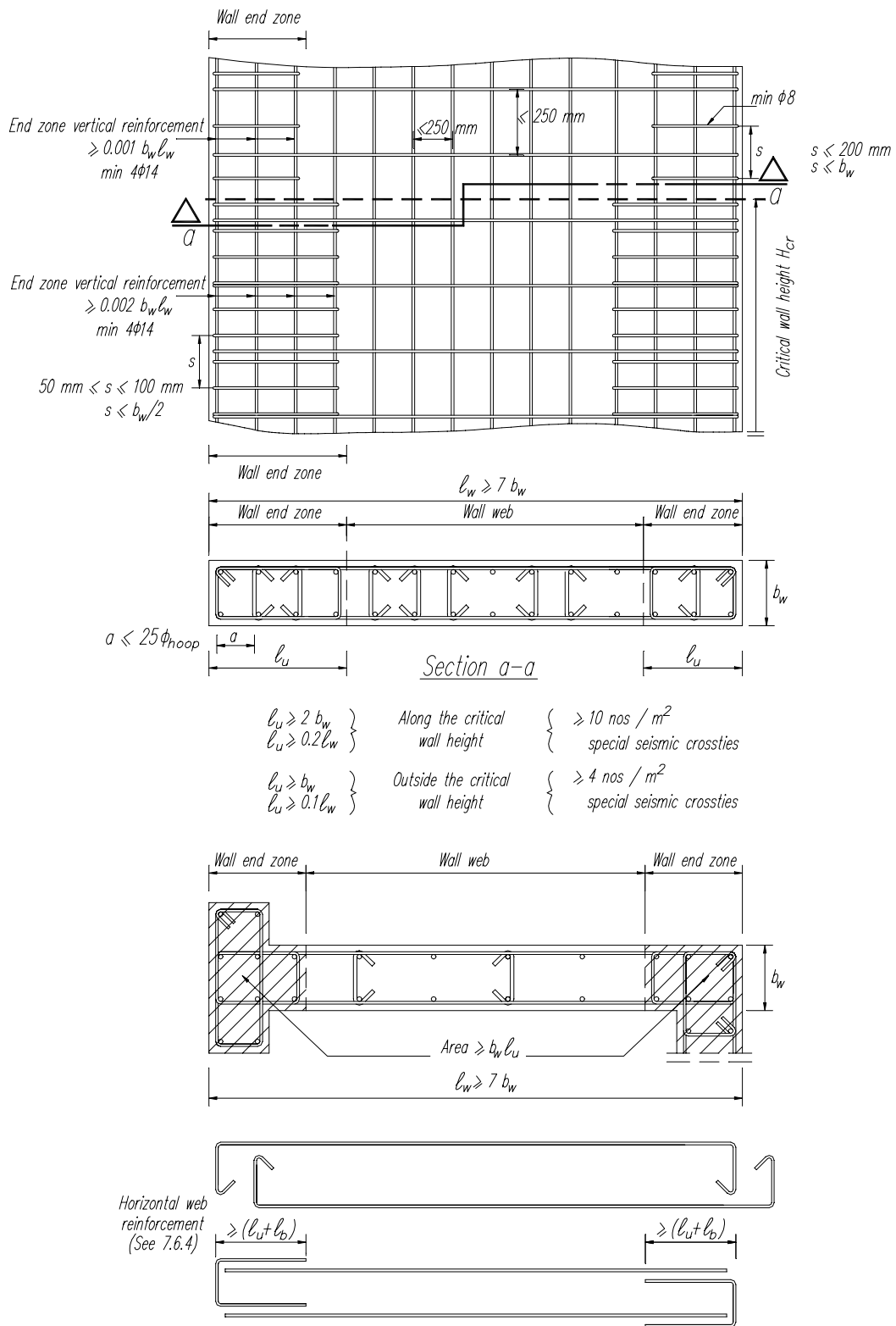

Figure 7.11

(a) Diameter of transverse reinforcement to be used at wall end zones shall not be less than 8 mm. Horizontal distance between the legs of hoops and/or crossties, **a**, shall not be more than 25 times the diameter of hoops or crossties.

(b) At least 2/3 the transverse reinforcement determined by Eq.(7.1b) in 7.3.4.1 for the confinement zones of columns shall be provided at wall end zones along the *critical wall height* defined in 7.6.2.2. Vertical spacing of hoops and/or crossties shall not be more than half the wall thickness and 100 mm, nor shall it be less than 50 mm (Fig. 7.11). Such reinforcement shall be extended into the foundation by at least a height equal to twice the wall thickness.

(c) Vertical spacing of hoops and/or crossties at wall end zones outside the critical wall height shall not be more than the wall thickness and 200 mm (Fig. 7.11). However, diameter and spacing of the transverse reinforcement at wall end zones shall in no case be less than those of the horizontal web reinforcement.

7.6.6. Design Bending Moments

7.6.6.1 - In walls satisfying the condition $H_w / \ell_w > 2.0$, design bending moments along the critical wall height determined according to 7.6.2.2 shall be taken as a constant value being equal to the bending moment calculated at the wall base in accordance with Chapter 6. Above the critical wall height, a linear bending moment diagram shall be applicable which is parallel to the line connecting the moments calculated at the base and at the top of the wall (Fig. 7.12). In buildings with rigid peripheral walls at basements, the constant wall bending moment shall be considered along the critical wall height defined in 7.6.2.2.

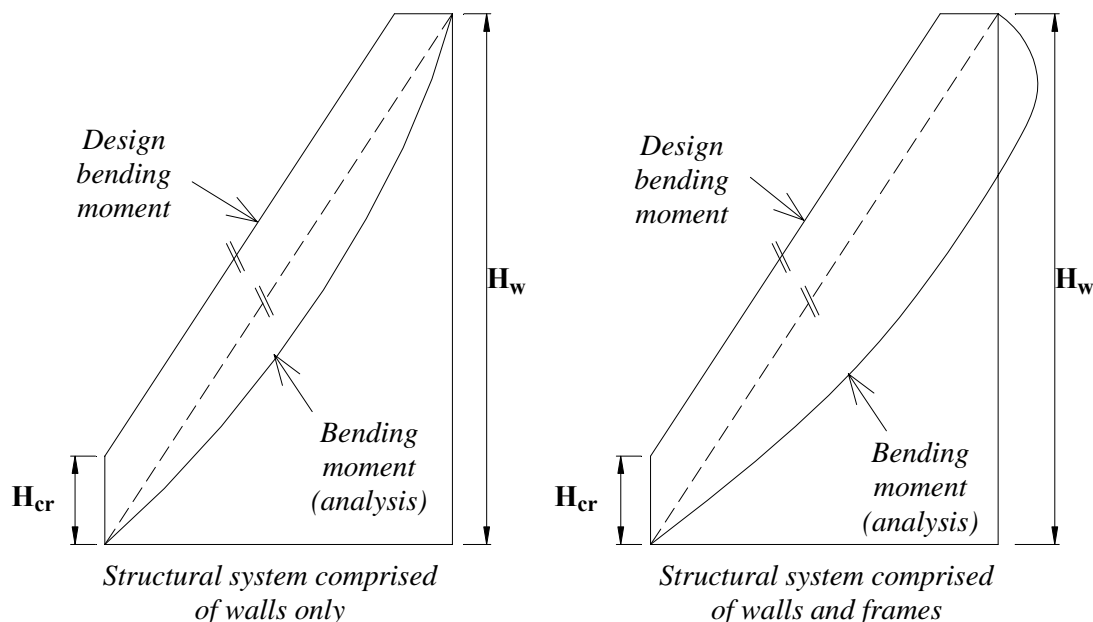

Figure 7.12

7.6.6.2 – In the case where $H_w / \ell_w > 2.0$, ultimate moment resistances of wall cross sections at each storey shall satisfy in their strong direction the condition given by **Eq.(7.3)** for columns. Otherwise, seismic analysis shall be repeated by increasing the wall dimensions and/or reinforcement.

7.6.7. Shear Safety of Structural Walls

7.6.7.1 – The shear force V_d shall be taken into account in calculating the transverse reinforcement in walls or wall segments.

7.6.7.2 - Shear strength of wall cross sections, V_r , shall be calculated by **Eq.(7.16)**.

$$V_r = A_{ch} (0.65 f_{ctd} + \rho_{sh} f_{yd}) \quad (7.16)$$

The shear force V_d shall satisfy the conditions defined below:

$$V_d \leq V_r \quad (7.17a)$$

$$V_d \leq 0.22 A_{ch} f_{cd} \quad (7.17b)$$

Otherwise wall cross sections shall be increased so as to satisfy the above conditions.

7.6.7.3 – At construction joints at the foundation level and at the above stories, *shear friction* design defined in TS-500 shall be performed.

7.6.8. Rules and Requirements for Coupled Structural Walls

7.6.8.1 – All rules and requirements given above for structural walls are equally valid for each of the wall segments forming the coupled structural walls.

7.6.8.2 – Sum of the base moments developed along the given earthquake direction at the wall segments forming a coupled structural wall system shall not be more than 2/3 the total overturning moment developed in the coupled structural wall system due to seismic loads (**Fig. 7.13**). In the case where this condition is not satisfied, each of the wall segments forming the coupled structural wall shall be treated as a solid structural wall, and **R** factor taken from **Table 6.5** of **Chapter 6** shall be changed accordingly.

7.6.8.3 – In the reinforcement design of wall segments forming the coupled structural wall, it may be allowed to transfer at most 30 % of the moment of the wall segment in tension to the wall segment in compression (*redistribution*).

7.6.8.4 – Rules related to the shear reinforcement of coupling beams are given below:

(a) In the case where any of the conditions below is satisfied, calculation of shear reinforcement of coupling beams shall be performed in accordance with **7.4.5**.

$$\ell_n > 3 h_k \quad (7.18a)$$

$$V_d \leq 1.5 b_w d f_{ctd} \quad (7.18b)$$

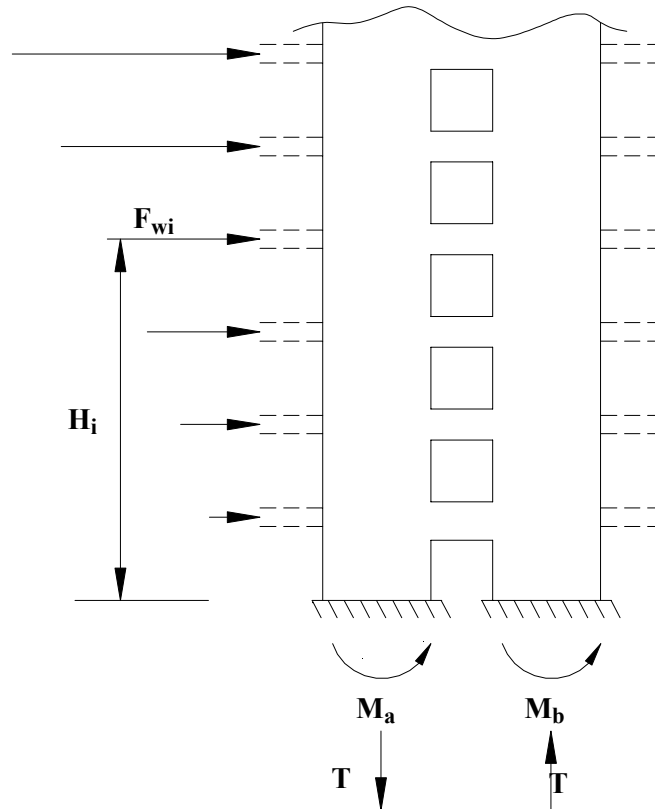

$$(M_a + M_b) \leq 2/3 \sum F_{wi} H_i \quad F_{wi} : \text{Seismic load acting at } i\text{'th storey on coupled structural wall system}$$

Figure 7.13

(b) In the case where none of the conditions given by Eq.(7.18) is satisfied, the special shear reinforcement to be provided for the coupling beam shall be determined by methods whose validity are proven by tests, or cross rebars shall be used to resist the shear of the coupling beam (Fig. 7.14). Total reinforcement area of each bundle of cross rebars shall be determined by Eq.(7.19).

$$A_{sd} = V_d / (2 f_{yd} \sin \gamma) \quad (7.19)$$

There shall be at least four rebars in each bundle of cross rebars and they shall be extended into the wall segments by at least $1.5 \ell_b$. Bundles shall be confined with special seismic hoops whose diameter shall not be more than 8 mm and their spacing shall not be more than 6 times the cross rebar diameter and 100 mm. In addition to cross rebars, coupling beam shall be provided with the minimum amount of hoops and horizontal web reinforcement specified in TS-500 (Fig. 7.14).

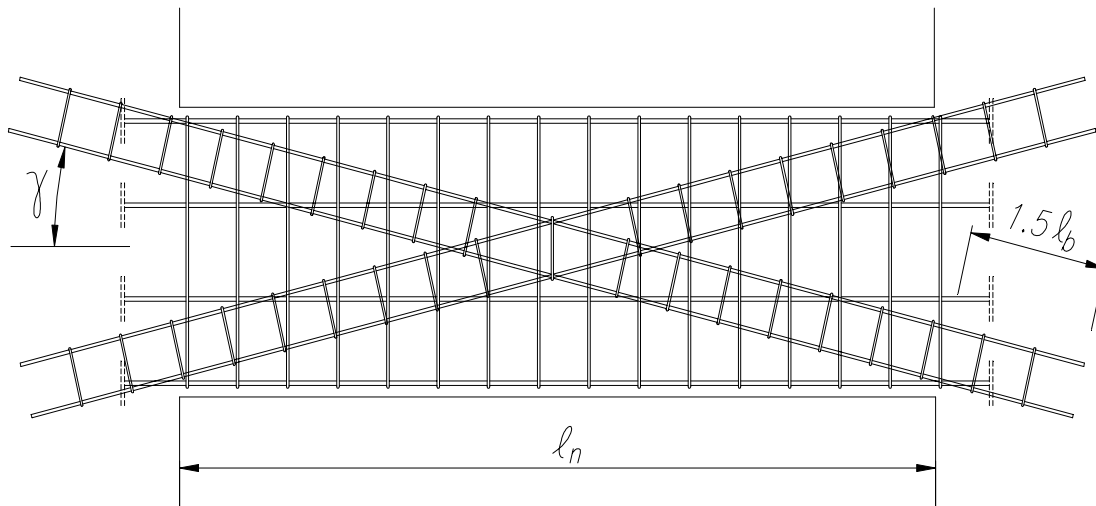

Figure 7.14

7.7. COLUMNS OF NOMINAL DUCTILITY LEVEL

7.7.1. Cross-section Requirements

Cross-section requirements given in **7.3.1** for columns of high ductility level are equally applicable to columns of nominal ductility level.

7.7.2. Longitudinal Reinforcement Requirements

Longitudinal reinforcement requirements given in **7.3.2** for columns of high ductility level are equally applicable to columns of nominal ductility level.

7.7.3. Arrangement of Longitudinal Reinforcement

Requirements related to the arrangement of longitudinal reinforcement given in **7.3.3** for columns of high ductility level are equally applicable to columns of nominal ductility level with the exception of para. (c) of **7.3.3.2**.

In the case where reinforcement lap splices are made at the bottom end of the column, minimum transverse reinforcement defined in **7.7.4.1** shall be used along the length of the lap splice.

7.7.4. Transverse Reinforcement Requirements

The minimum transverse reinforcement requirements of columns are specified in **7.7.4.1** for *column confinement zones* and in **7.7.4.2** for the *column central zone*. *Special seismic hoops* and *special seismic cross ties* defined in **7.2.8** shall be used along all regions of column.

7.7.4.1 – The definition given in **7.3.4.1** for the length of each of the confinement zones is equally applicable to columns of nominal ductility level.

In columns of nominal ductility level, spacing of transverse reinforcement along the confinement zones shall be half the spacing of hoops provided in the column central zone in accordance with below given **7.7.4.2**.

7.7.4.2 – In relation to the column central zone, definition and the minimum transverse reinforcement requirements given in **7.3.4.2**, as well as the conditions given in **7.3.4.3** are equally applicable to columns of nominal ductility level. Transverse reinforcement in column central zone shall be determined in accordance with **7.7.5.3**.

7.7.5. Shear Safety of Columns

7.7.5.1 – In columns of nominal ductility level, the shear force, V_d , obtained under the combined effect of gravity loads and seismic loads given in **Chapter 6** shall be taken into account in the determination of transverse reinforcement.

7.7.5.2 – In relation to the upper bound of shear force, the condition given by **Eq.(7.7)** for columns of high ductility level is equally applicable to columns of nominal ductility level, provided that V_d shall be considered in lieu of V_e .

7.7.5.3 – In the determination of transverse reinforcement according to the shear force defined in **7.7.5.1**, the contribution of concrete to the shear strength of the section, V_c , shall be determined in accordance with TS-500 by taking into account the minimum axial force, N_d , calculated under gravity loads combined with seismic loads.

7.7.6. Conditions Related to Short Columns

In relation to short columns, conditions given in **7.3.8** for columns of high ductility level are equally applicable to columns of nominal ductility level.

7.8. BEAMS OF NOMINAL DUCTILITY LEVEL

7.8.1. Cross-section Requirements

Cross-section requirements given in **7.4.1.1** for beams of high ductility level are equally applicable to beams of nominal ductility level.

7.8.2. Longitudinal Reinforcement Requirements

Longitudinal reinforcement requirements given in **7.4.2** for beams of high ductility level are equally applicable to beams of nominal ductility level.

7.8.3. Arrangement of Longitudinal Reinforcement

Requirements related to the arrangement of longitudinal reinforcement given in **7.4.3** for columns of high ductility level are equally applicable to columns of nominal ductility level.

7.8.4. Transverse Reinforcement Requirements

A region with a length twice the beam depth measured from the column face of a beam support shall be defined as *confinement zone* and *special seismic hoops* defined in 7.2.8 shall be used along this region. In the confinement zone, distance of the first hoop to the column face shall be max. 50 mm. Unless a more unfavourable value is obtained from the below given 7.8.5, hoop spacing shall not exceed 1/4 the beam depth, 8 times the minimum diameter of the longitudinal reinforcement and 200 mm. Outside the confinement zone, minimum transverse reinforcement requirements specified in TS-500 shall be applied.

7.8.5. Shear Safety of Beams

7.8.5.1 – In beams of nominal ductility level, the shear force, V_d , obtained under the combined effect of gravity loads and seismic loads given in **Chapter 6** shall be taken into account in the determination of transverse reinforcement.

7.8.5.2 – In relation to the upper bound of shear force, the condition given by **Eq.(7.7)** for beams of high ductility level is equally applicable to beams of nominal ductility level, provided that V_d shall be considered in lieu of V_e .

7.8.5.3 – In the determination of transverse reinforcement according to the shear force defined in 7.8.5.1, the contribution of concrete to the shear strength of the section, V_c , shall be determined in accordance with TS-500. In no case shall the contribution of inclined longitudinal bars to the shear strength be taken into account.

7.9. BEAM-COLUMN JOINTS OF FRAME SYSTEMS OF NOMINAL DUCTILITY LEVEL

Rules and conditions given in 7.5 in relation to beam-column joints of frame systems formed by columns and beams of high ductility level are equally applicable to beam-column joints of systems of nominal ductility level with the exception of 7.5.2.1 and 7.5.2.2.

7.10. STRUCTURAL WALLS OF NOMINAL DUCTILITY LEVEL

Structural walls of nominal ductility level shall be dimensioned and reinforced in accordance with the internal forces developed under the combined effect of gravity loads and seismic loads. With the exception of rules and conditions given in 7.6.6, 7.6.8.2, 7.6.8.3 as well as the definitions and conditions given in relation to the *critical wall height*, rules and conditions given in 7.6 for structural walls of high ductility level are equally applicable to structural walls of nominal ductility level.

7.11. SLABS

7.11.1 – Slabs shall possess sufficient stiffness and strength to enable the safe distribution of seismic loads acting on storey masses to the vertical elements of the structural system.

7.11.2 – In all seismic zones, slab thickness of all cast-in-situ or prefabricated, bare or infilled joist floor systems shall not be less than 50 mm. However it is mandatory that

shear connectors be made between joists and the slab, and their adequacy be proven by calculation to insure the safe transfer of in-plane shear forces developed under gravity loads and seismic loads. Requirements given in TS-500 for the slab thicknesses of other floor systems are applicable.

7.11.3 – In relation to the shear strength of slab systems, conditions given in **7.6.7** for the shear strength of structural walls of high ductility level are equally applicable.

7.12. SPECIAL REQUIREMENTS FOR PREFABRICATED BUILDINGS

Prefabricated buildings which are constructed through assembling the structural elements manufactured in factory conditions shall comply with the following special requirements in addition to the other requirements specified in this regulation.

7.12.1. Frames with Hinge Connections

7.12.1.1 – With the exception of single storey industrial-type buildings, prefabricated frame type structural systems with hinge connections (which are unable to resist moments) may be permitted provided that reinforced concrete cast-in-situ structural walls are constructed in both directions to fully resist against the seismic loads.

7.12.1.2 – Welded hinge connections and other hinge connections shall possess sufficient strength to resist 1.5 times and 1.2 times the seismic connection forces, respectively, obtained according to **Chapter 6**.

7.12.2. Moment Resisting Frames

7.12.2.1 – It shall be proven through analytical methods with appropriate references from the literature or tests that moment resisting connections of prefabricated building frames possess strength and ductility that are equivalent to the monolithic behaviour under cyclic and repeated loading due to earthquakes.

7.12.2.2 – Connections shall possess sufficient strength to transfer moments, shear forces and axial forces to be developed at the ultimate strength level without any reduction in strength and ductility. In welded connections and other type of connections, 1.5 times and 1.2 times the seismic connection forces, respectively, obtained according to **Chapter 6** shall be taken into account.

7.12.2.3 – Connections must be arranged in sufficient distance from the potential plastic hinges that can develop within the elements connected.

7.12.3. Prestressing Conditions

With the exception of floor elements and girder type elements with hinge connections to the columns of single-storey buildings, full prestressing shall not be permitted in prefabricated structural elements to be used in seismic zones. Appropriate amount of non-prestressing steel reinforcement shall be used to achieve a sufficient ductility. Such reinforcement shall comply with the requirements given in TS-3233.

7.13. REQUIREMENTS FOR REINFORCED CONCRETE APPLICATION DESIGN DRAWINGS

7.13.1. General Requirements

7.13.1.1 – Quality classes of concrete and reinforcing steel to be used in the building shall be indicated on all drawings.

7.13.1.2 – The *Effective Ground Acceleration Coefficient*, the *Building Importance Factor* considered in the design, the *Local Site Class* selected from **Table 12.2** and the *Structural Behaviour Factor* determined from **Table 6.5** shall be indicated on all floor framing plan drawings.

7.13.1.3 – Hook bending detail of special seismic hoops and special seismic crossties defined in 7.2.8 (**Fig. 7.1**) shall be shown on all detail drawings of columns, beams and structural walls.

7.13.2. Column and Beam Details

7.13.2.1 – Position, diameter and number of vertical rebars within the cross-section shall be shown in detail on column application drawings. Further, horizontal sections shall be taken at each beam-column joint showing in plan the rebars extended upwards from the column below and longitudinal rebars of all beams framing into the column. Hence it shall be clearly shown that column and beam rebars are arranged in such a way that they shall not hinder the proper pouring of concrete into the joint.

7.13.2.2 – Vertical sections shall be taken with vertical rebar detailing clearly shown for each type of column with fully identical longitudinal and transverse reinforcement. Vertical column sections shall include rebar splicing regions, lap lengths, beam-column joint at the top of the column. In this respect, standard details valid for all beam-column joints of the building shall not be accepted.

7.13.2.3 – Lengths of column confinement zones as well as diameters, numbers, spacing and cross-sectional details of transverse reinforcement provided along those regions, along the column central zone and within the top beam-column joint shall be clearly indicated on the drawings, separately for each column type.

7.13.2.4 – In the application drawings of structural walls; positions, diameters and numbers of vertical bars in the web and wall end zones shall be indicated. In addition, vertical sections shall be taken for each wall type showing the vertical layout of rebars. Critical wall height shall be clearly indicated on the vertical section. Diameters, numbers, spacing and cross-sectional details of transverse reinforcement provided along the critical wall height and other sections of the wall shall be clearly indicated on the drawings.

7.13.3. Beam Details

In beam details, lengths of confinement zones at beam supports as well as diameters, numbers, spacing and cross-sectional details of transverse reinforcement provided along those regions and along the beam central zone shall be clearly indicated on the drawings, separately for each beam.

CHAPTER 8 - EARTHQUAKE RESISTANT DESIGN REQUIREMENTS FOR STRUCTURAL STEEL BUILDINGS

8.0. NOTATION

E	= Notation for seismic load
G	= Notation for dead load
M_{pa}	= Plastic moment calculated at the bottom end of column
M_{pi}	= Positive or negative plastic moment calculated at the left end i of the beam
M_{pj}	= Negative or positive plastic moment calculated at the right end j of the beam
M_{pü}	= Plastic moment calculated at the top end of column
Q	= Notation for live load
V_{ik}	= Sum of shear forces calculated in the earthquake direction considered in accordance with Chapter 6 at all columns of the i'th storey
V_{is}	= Sum of shear forces calculated in the earthquake direction considered in accordance with Chapter 6 at the i'th storey columns where Eq.(8.2) is satisfied at both bottom and top joints
α_i	= Ratio of V_{is} / V_{ik} calculated for any i'th storey

8.1. SCOPE

8.1.1 - Dimensioning of all structural elements of structural steel buildings to be built in seismic zones and design of their joints shall be performed, along with currently enforced relevant standards and codes, primarily in accordance with the requirements of this chapter.

8.1.2 - Lateral load carrying systems of structural steel buildings covered in this chapter may be comprised of steel frames only, of steel braced frames only or of combination of frames with steel braced frames or reinforced concrete structural walls.

8.1.3 - Requirements for structural steel building foundations are given in **Chapter 12**.

8.2. GENERAL RULES

8.2.1. Classification of Steel Structural Systems

Lateral load carrying systems of structural steel buildings shall be classified with respect to their seismic behaviour into two classes defined below. Special cases and requirements regarding the mixed use of such classes of systems are given in **6.5.4** of **Chapter 6**. In the case where reinforced concrete structural walls are used as part of the structural system, rules given in **7.6** or **7.10** of **Chapter 7** shall be applied.

8.2.1.1 - Structural steel systems given below are defined as *Systems of High Ductility Level*:

(a) Frame type structural systems complying with the requirements of **8.3**.

(b) Structural systems comprised of eccentric steel braced frames complying with the requirements of **8.4**.

(c) Steel braced frame-frame systems made of combining the two systems defined above.

8.2.1.2 – Structural steel systems given below are defined as *Systems of Nominal Ductility Level*:

(a) Frame type structural systems complying with the requirements of **8.5**.

(b) Structural systems comprised of concentric steel braced frames complying with the requirements of **8.6**.

(c) Steel braced frame-frame systems made of combining the two systems defined above.

8.2.2. Relevant Standards

Design of structural steel systems covered in the scope of this chapter shall be performed according to the seismic loads and analysis requirements given in **Chapter 6** of this Specification, to other loads specified in TS-498, to the requirements of TS-648 and TS-3357 based on allowable stress method and to those of TS-4561 based on ultimate strength design method. However, it shall be considered that TS-4561 is applicable to buildings up to two stories when structural systems are comprised of frames only.

8.2.3. Allowable Stresses, Load and Material Safety Factors

8.2.3.1 – In section design to be performed with *Allowable Stress Method*, 15% increase permitted for allowable stresses in TS-648 for loading case EYY may be amplified up to 33% except for joints and splices.

8.2.3.2 – In section design to be performed with *Ultimate Strength Method*, load factors given in TS-4561 for load combinations including seismic load shall be modified as follows:

$$1.0 G + 1.0 Q \pm 1.0 E \quad (8.1a)$$

or in the case where more unfavourable results are obtained,

$$0.9 G \pm 1.0 E \quad (8.1b)$$

In section design to be performed according to TS-4561 with *Ultimate Strength Method*, material safety factor applicable to steel yield strength shall be taken as **1.15** whereas material safety factor applicable to concrete characteristic compressive strength shall be taken as **1.5**.

8.2.3.3 – In all seismic zones, allowable stress or ultimate strength of welding shall be decreased by 25%. In the first and second seismic zones, welded connections and splices at site shall be done by certified welders.

8.3. FRAMES OF HIGH DUCTILITY LEVEL

8.3.1. Cross-section Requirements

Requirements given in TS-4561, Clause 2.5.4 shall be applied for *flange width/thickness* ratio and *web depth/thickness* ratio of all frame elements, even if section design is performed with *Allowable Stress Method* according to TS-648.

8.3.2. Requirement of Having Columns Stronger Than Beams

8.3.2.1 - In frame systems or in the frames of frame-wall (braced frame) systems, sum of the plastic moments of columns framing into a beam-column joint in the earthquake direction considered shall be more than the sum of plastic moments of beams framing into the same joint (**Fig. 8.1**):

$$(M_{pa} + M_{pü}) \geq (M_{pi} + M_{pj}) \quad (8.2)$$

Eq.(8.2) shall be applied separately for both senses of earthquake direction to yield the most unfavourable result. In calculating the column plastic moments, axial forces shall be considered to yield the minimum moments consistent with the sense of earthquake direction.

Eq.(8.2) need not to be checked in single storey buildings and in joints of topmost storey of multi-storey buildings.

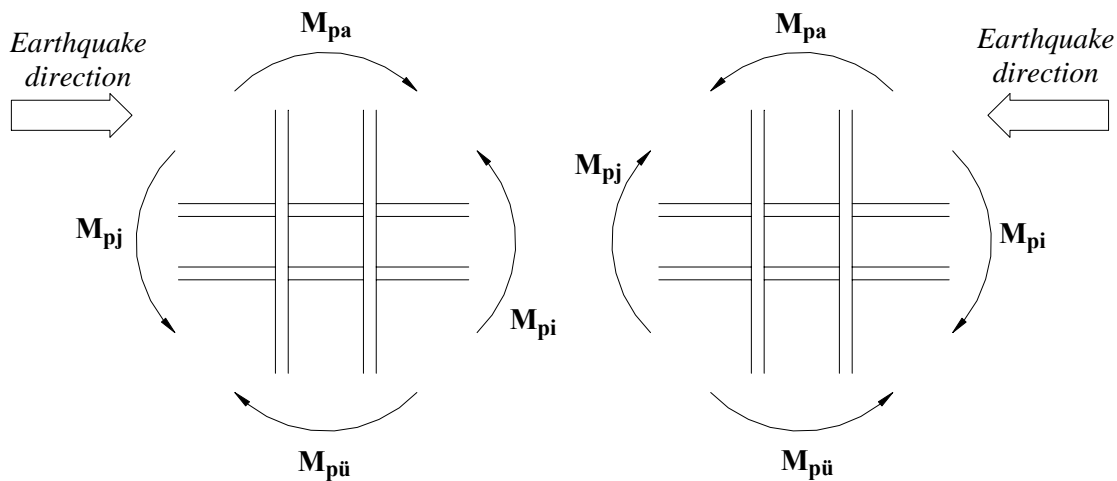

Figure 8.1

8.3.3. The Case Where Some Columns Cannot Satisfy the Requirement of Having Columns Stronger Than Beams

8.3.3.1 – In structural systems comprised of frames only or of combination of frames and walls (braced frames), **Eq.(8.2)** may be permitted not to be satisfied in a given earthquake direction at some joints at the bottom and/or top of an *i*'th storey, provided that **Eq.(8.3)** given below is satisfied.

$$\alpha_i = V_{is} / V_{ik} \geq 0.70 \quad (8.3)$$

8.3.3.2 – In the case where **Eq.(8.3)** is satisfied, bending moments and shear forces of columns satisfying **Eq.(8.2)** at both bottom and top joints shall be amplified by multiplying with the ratio $(1/\alpha_i)$ within the range of $0.70 < \alpha_i < 1.00$.

8.3.3.3 – In the case where **Eq.(8.3)** is not satisfied at any storey, all frames of structural systems which may be comprised of frames only or of combination of frames and walls (braced frames) shall be considered as *frames of nominal ductility level*, and the analysis shall be repeated by changing the Structural Behaviour Factor according to **Table 6.5**. As it is mentioned in **6.5.4.2** in **Chapter 6**, it is possible, however, to combine frames of nominal ductility level with structural walls (braced frames) of high ductility level.

8.3.4. Splices and Connections of Frames

8.3.4.1 – The column shall be continuous in beam-column joints of frames. In the case where the beam is connected to the column flange, web of the column shall be strengthened at the beam flange level by stiffening plates.

8.3.4.2 – In the first and second seismic zones, common bolts shall not be used in connections and splices transferring moments. However prestressed high strength bolts and anchor bolts are exempted from this restriction. High strength bolts shall be of ISO 8.8 or 10.9 quality.

8.3.4.3 – Column splices shall be made away from beam-column joint by at least 1/4 the storey height. In the case of splices with butt welds, edge preparation and deep penetration welding shall be applied.

8.3.4.4 – Load transfer strength of beam-column joints with fillet welds or non-prestressed bolts shall not be less than 1.2 times the strength of element connected to the joint. Load transfer strength of other types of beam-column joints shall not be less than the strength of element connected to the joint.

8.3.4.5 – Beam splices shall be made away from the beam-column connection by a distance at least equal to beam height.

8.3.4.6 – Design calculations of connection and splices shall be given in detail in the design report.

8.4. STEEL BRACED FRAMES OF HIGH DUCTILITY LEVEL

Steel braced frames of high ductility level are defined as lateral load resisting structural elements comprised of columns, beams and braces with *eccentric connections to joints*. Requirements to be applied to such elements are as specified below:

8.4.1 – Eccentricity of a brace with respect to a beam-column joint or the eccentricities of two braces with respect to a common joint on a beam shall be selected as 1/5 to 1/10 of the span length in between columns. Necessary measures shall be taken to prevent the lateral buckling of beam and local buckling at the connections of eccentric braces to beams.

8.4.2 – In braced frames where braces are connected to columns, connections shall be made at the column flange. Connection shall not be made to web of the column.

8.4.3 – Slenderness ratio of braces designed to resist compressive forces too shall not be more than 100.

8.4.4 – Regarding brace cross-sections made up multiple elements to resist compressive forces, rules given in TS-648 for intermediate coupling elements are applicable.

8.4.5 – In the case where common bolts are used for brace connections, allowable stresses of bolts shall be reduced by 33%.

8.5. FRAMES OF NOMINAL DUCTILITY LEVEL

8.5.1 – Requirements given above in **8.3.1**, **8.3.2** and **8.3.3** for frames of high ductility level are not mandatory to be applied for frames of nominal ductility level.

8.5.2 – Requirements given above in **8.3.4** for frames of high ductility level are also applicable to frames of nominal ductility level excluding **8.3.4.2**.

8.5.3 – In design calculations of splices and connections of frames of nominal ductility level, twice the internal forces obtained according to **Chapter 6** shall be used.

8.6. STEEL BRACED FRAMES OF NOMINAL DUCTILITY LEVEL

Steel braced frames of nominal ductility level are defined as lateral load resisting structural elements comprised of columns, beams and braces with *concentric connections to joints*. Requirements to be applied to such elements are as specified below:

8.6.1 – In the case where braces are designed to resist tension only, slenderness ratio of braces shall not exceed 250.

8.6.2 – Slenderness ratio of braces designed to resist compressive forces too shall not be more than 100.

8.6.3 – Regarding brace cross-sections made up multiple elements to resist compressive forces, rules given in TS-648 for intermediate coupling elements are applicable.

8.6.4 – In the case where common bolts are used for brace connections, allowable stresses of bolts shall be reduced by 33%.

CHAPTER 9 - EARTHQUAKE RESISTANT DESIGN REQUIREMENTS FOR TIMBER BUILDINGS

9.1. SCOPE

Design of timber buildings or building-like structures constructed in seismic zones with load-bearing walls carrying both vertical and lateral loads as well as floors made of timber skeleton shall be performed, along with currently enforced relevant standards and codes, primarily in accordance with the requirements of this chapter. Rules for the foundations of timber buildings are given in **Chapter 12**.

9.2. GENERAL RULES

9.2.1 – All the rules given in this chapter for the dimensioning of timber buildings shall be followed and an analysis based on **Chapter 6** shall not be performed.

9.2.2 – In all seismic zones, timber buildings shall be constructed with maximum two stories excluding basements.

9.2.3 – Basements of timber buildings, if any, shall be made as masonry construction in accordance with the rules given in **Chapter 10**. Ground storey may also be made as masonry construction in accordance with **Chapter 10**.

9.2.4 – Storey height of timber buildings, excluding basement, shall not be more than 3 m from one floor top level to the other. In the case where a basement is made, height of this shall not be more than 2.40 m.

9.2.5 – Load-bearing walls of timber buildings shall be arranged in plan, as much as possible, regularly and symmetric or nearly symmetric with respect to the main axes. At all stories, load-bearing walls shall be placed one over the other. When possible, construction of partial basement shall be avoided.

9.3. LOAD-BEARING WALLS

9.3.1. Load-Bearing Skeleton of Wall

9.3.1.1 – The timber skeleton of load-bearing walls shall be comprised of the following elements:

- (a) *Posts* with maximum 1.5 m spacing,
- (b) *Base beams* to be placed under the posts,
- (c) *Head beams* to be placed above the posts,
- (d) *Horizontal intermediate beams* connecting posts along the wall together with base and head beams to form rectangular holes in the wall,
- (e) *Braces* converting rectangular holes into triangular holes.

9.3.1.2 – In single-storey timber buildings, cross section dimensions of base and head beams as well as of braces shall be at least 10 cm x 10 cm, and cross section dimensions of intermediate beams shall be at least 5 cm x 10 cm.

9.3.1.3 – In buildings where both stories are of timber, cross section dimensions of base and head beams as well as of braces shall be at least 12 cm x 12 cm, and cross section dimensions of intermediate beams shall be at least 6 cm x 12 cm.

9.3.1.4 – Posts and braces shall be made of a single piece. Splicing may be made at base and head beams. Splices shall be made in the form of face-to-face overlapping with connections made by bolts or nails having lengths equal to beam thickness (**Fig. 9.1**).

9.3.1.5 – Posts and braces shall be connected to base or head beams by interlocking, and in addition connection shall be strengthened by nails. In the case where interlocked connection cannot be made, corner plugs shall be used with nail connections (**Fig. 9.2**).

9.3.1.6 – Other element connections shall be in the form of straight or curved grooves.

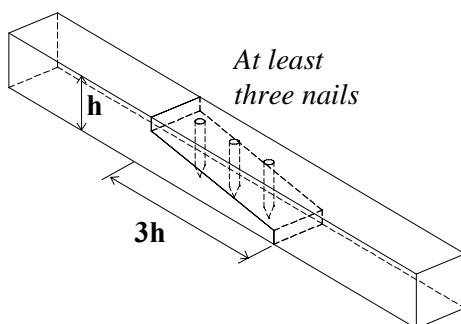

Figure 9.1

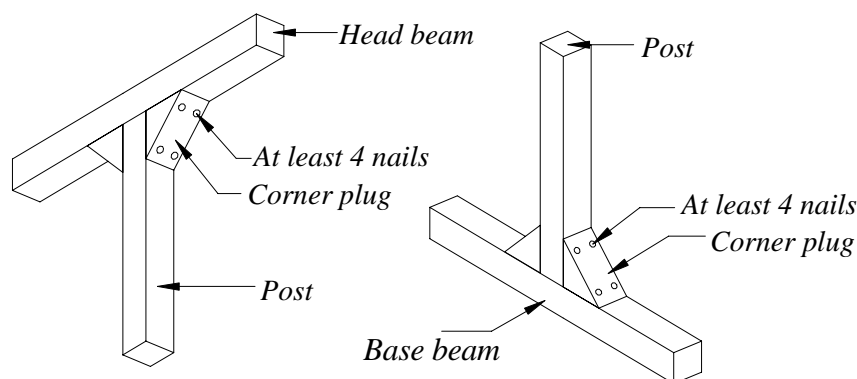

Figure 9.2

9.3.2. Minimum Total Length of Load-Bearing Walls

The ratio of the total length of timber load-bearing walls in each of the orthogonal directions in plan (excluding window and door openings), to gross floor area (excluding cantilever floors) shall not be less than $(0.20 I) \text{ m/m}^2$ where **I** represents Building Importance Factor defined in **Chapter 6**.

9.3.3. Maximum Unsupported Length of Load-Bearing Walls

Unsupported length of a load-bearing wall between the connecting wall axes in the perpendicular direction shall not exceed 4.5 m. Otherwise, posts shall be connected by braces to floor beams or roof trusses with a maximum spacing of 4.5 m (**Fig. 9.3**).

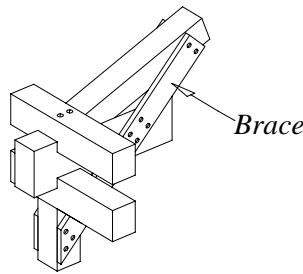

Figure 9.3

9.3.4. Openings in Load-Bearing Walls

9.3.4.1 – Plan length of the load-bearing wall segment between the corner of a building and the nearest window or door opening to the corner shall not be less than 1.5 m.

9.3.4.2 – Excluding the corners of buildings, plan lengths of the load-bearing wall segments between the window or door openings shall not be less than 0.75 m.

9.3.5. Lintels and Bond Beams

9.3.5.1 – Lintels and bond beams of buildings with masonry ground floor shall be made in accordance with the rules given in **Chapter 10**.

9.3.5.2 – Lintels at the top of doors and those at the bottom and top of windows shall have an identical cross section of posts, and lintels shall be connected to posts by interlocking joints.

9.3.6. Infilling and Finishing of Walls

9.3.6.1 – Triangular holes obtained in the load-bearing walls in accordance with **9.3.1.1** above, shall be filled with light bricks, adobe blocks, chipped wood or other appropriate insulation material.

9.3.6.2 – Wall surfaces shall be covered by wooden plates or corrugated wall finishes, or they shall be plastered by covering wire-mesh, wooden strips or similar.

9.4. FLOORS AND ROOFS

Floors and roofs of timber buildings shall also be timber. Floor beams of the ground floor shall be supported by base beams whereas those of the other stories and roof trusses shall be supported by head beams with nailed connections (**Fig. 9.4**).

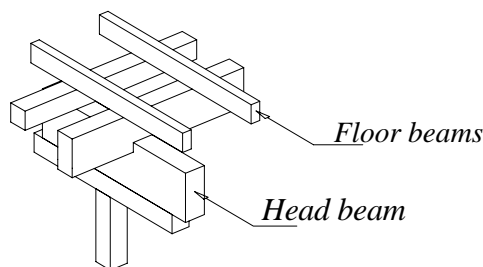

Figure 9.4

CHAPTER 10 - EARTHQUAKE RESISTANT DESIGN REQUIREMENTS FOR MASONRY BUILDINGS

10.1. SCOPE

Dimensioning and reinforcing of masonry buildings and building-like structures to be constructed in seismic zones with load-bearing walls of natural or artificial materials, to resist both vertical and lateral loads shall be performed, along with currently enforced relevant standards and codes, primarily in accordance with the requirements of this chapter. Requirements for masonry building foundations are given in **Chapter 12**.

10.2. GENERAL RULES

10.2.1 – In the case when all the rules given in this chapter for masonry buildings are followed, seismic analysis according to **Chapter 6** is not required. However when seismic analysis is performed, analysis method given in 6.7 of **Chapter 6** shall be applied by taking $S(T_1) = 2.5$ and $R_a(T_1) = 2.5$, provided that all the rules given in this chapter are followed.

10.2.2 – With the exception of a special case given in **10.5.2** below, maximum number of stories permitted are given in **Table 10.1** depending on seismic zones.

10.2.3 – Maximum number of stories given in **Table 10.1** correspond to ground storey plus the upper stories. In addition to those, a penthouse with gross area not exceeding 25% of the building area at foundation level and a single basement may be built. The penthouse not satisfying the 25% rule shall be deemed to be a full storey. In the case where more than a single basement is constructed, maximum number of stories given in **Table 10.1** shall be reduced by one.

10.2.4 – Storey height of masonry buildings shall not be more than 3 m from one floor top level to the other.

10.2.5 – Load-bearing walls of masonry buildings shall be arranged in plan, as much as possible, regularly and symmetric or nearly symmetric with respect to the main axes. When possible, construction of partial basement shall be avoided.

10.2.6 - In plan, load-bearing walls shall be constructed so as to be placed one over the other.

**TABLE 10.1 – MAXIMUM NUMBER OF STORIES PERMITTED
(Excluding a single basement)**

<i>Seismic Zone</i>	<i>Max. no of Stories</i>
1	2
2, 3	3
4	4

10.3. LOAD-BEARING WALLS

10.3.1. Load-Bearing Wall Materials

10.3.1.1 – Masonry materials to be used in the construction of load-bearing walls shall be natural stone, solid brick, bricks with vertical holes satisfying the maximum void ratios defined in TS-2510 and TS-705, solid concrete blocks and other similar blocks.

10.3.1.2 – Concrete blocks with holes, slag blocks, bricks with horizontal holes, bricks with vertical holes not satisfying the maximum void ratios defined in TS-2510 and TS-705, other bricks manufactured for infill walls in accordance with TS-4377, the “block” bricks, and similarly formed blocks shall never be used as load-bearing wall material.

10.3.1.3 – Natural stone load-bearing walls shall be used only in the basement and ground stories of masonry buildings.

10.3.1.4 – Concrete load-bearing walls shall be used only in the basements of masonry buildings.

10.3.1.5 – The minimum compressive strength of masonry structural materials shall not be less than 50 kg/cm^2 on the basis gross compression area. Compressive strength of natural stones to be used in basements shall be at least 100 kg/cm^2 . In the case where concrete walls are constructed in basements, quality of concrete to be used shall be at least **C16 (BS16)**.

10.3.1.6 – Mortars to be used in load-bearing walls shall be lime mortar enhanced with cement (*cement/lime/sand volumetric ratio=1/2/9*) or cement mortar (*cement/sand volumetric ratio=1/4*).

10.3.2. Minimum Thickness of Load-Bearing Walls

The minimum wall thicknesses, required to be applied to load-bearing walls, excluding plaster thicknesses, are given in **Table 10.2** depending on the number of stories. In the case of no basement, minimum wall thicknesses given in the table for ground storey and upper stories shall be applied. In penthouses permitted in accordance with **10.2.3**, wall thickness specified for the storey below shall be applied.

10.3.3. Minimum Total Length of Load-Bearing Walls

The ratio of the total length of masonry load-bearing walls in each of the orthogonal directions in plan (excluding window and door openings), to gross floor area (excluding cantilever floors) shall not be less than $(0.25 \text{ I}) \text{ m/m}^2$ where **I** represents Building Importance Factor defined in **Chapter 6**.

10.3.4. Maximum Unsupported Length of Load-Bearing Walls

10.3.4.1 - Unsupported length of a load-bearing wall between the connecting wall axes in the perpendicular direction shall not exceed 5.5 m. in the first seismic zone and 7.0 m in other seismic zones.

TABLE 10.2 - MINIMUM THICKNESSES OF LOAD-BEARING WALLS

<i>Seismic Zone</i>	<i>Stories Permitted</i>	<i>Natural Stone (cm)</i>	<i>Concrete (cm)</i>	<i>Brick (thickness)</i>	<i>Others (cm)</i>
1, 2, 3, 4	Basement	50	25	1	20
	Ground storey	50	—	1	20
1, 2, 3, 4	Basement	50	25	1.5	30
	Ground storey	50	—	1	20
	First storey	—	—	1	20
2, 3, 4	Basement	50	25	1.5	30
	Ground storey	50	—	1.5	30
	First storey	—	—	1	20
	Second storey	—	—	1	20
4	Basement	50	25	1.5	30
	Ground storey	50	—	1.5	30
	First storey	—	—	1.5	30
	Second storey	—	—	1	20
	Third storey	—	—	1	20

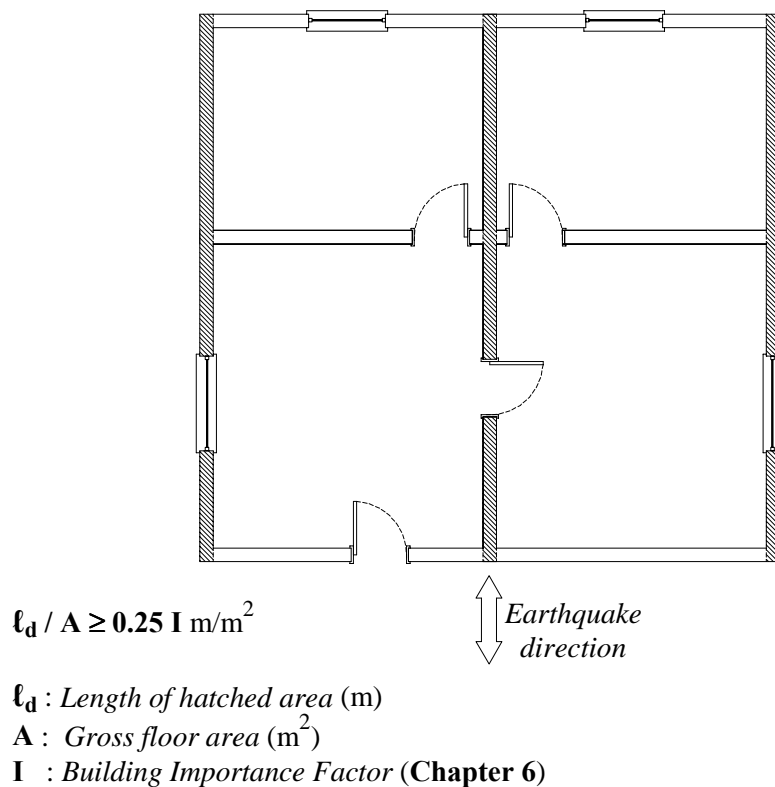

Figure 10.1

10.3.4.2 – In the case the condition given in **10.3.4.1** above is not satisfied, reinforced concrete vertical bond beams shall be constructed along the full storey height in accordance with below given **10.4.3** at the corners of building and in walls with axis to axis spacing in plan not more than 4.0 m. However unsupported length of such walls shall not be more than 16 m (**Figure 10.2**).

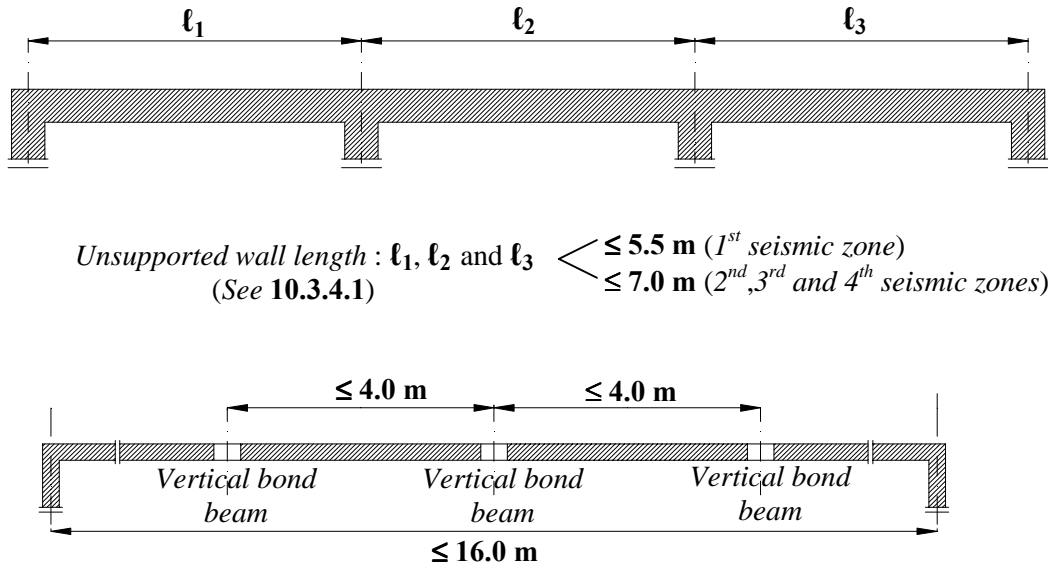

Figure 10.2

10.3.5. Openings in Load-Bearing Walls

The following rules shall be followed to provide openings in load-bearing walls (**Fig. 10.3**):

10.3.5.1 – Plan length of the load-bearing wall segment between the corner of a building and the nearest window or door opening to the corner shall not be less than 1.5 m in the first and second seismic zones and 1.0 m in the third and fourth seismic zones.

10.3.5.2 – Excluding the corners of buildings, plan lengths of the load-bearing wall segments between the window or door openings shall not be less than 1.0 m in the first and second seismic zones and 0.8 m in the third and fourth seismic zones.

10.3.5.3 – In the case where reinforced concrete vertical bond beams according to below given **10.4.3** are made on both sides of the window or door openings, minimum lengths of wall segments given in **10.3.5.1** and **10.3.5.2** may be decreased by 20%.

10.3.5.4 – Excluding the corners of buildings, plan length of a load-bearing wall segment between intersection of the orthogonal walls and the nearest window or door opening shall not be less than 0.5 m in the all seismic zones. Otherwise, reinforced concrete vertical bond beams according to below given **10.4.3** shall be made on both sides of the openings along the height of the storey.

10.3.5.5 – Plan length of each window or door opening shall not be more than 3.0 m.

10.3.5.6 – Total plan lengths of window or door openings along the unsupported length of any wall defined in **10.3.4** shall not be more than 40% of the unsupported wall length.

10.3.5.7 – In the case where reinforced concrete vertical bond beams according to below given **10.4.3** are made on both sides of the window or door openings, the maximum length of openings defined in **10.3.5.5** and the maximum ratio of openings defined in **10.3.5.6** may be increased by 20%.

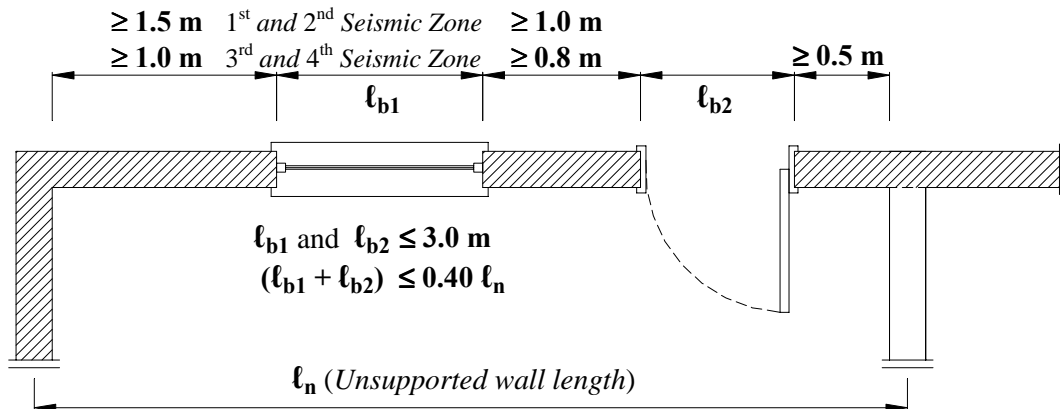

Figure 10.3

10.4. LINTELS AND BOND BEAMS

10.4.1. Lintels

10.4.1.1 – Each of seating lengths of window and door lintels on the walls shall not be less than 15% of lintel clear span nor shall it be less than 20 cm.

10.4.1.2 – Cross sections dimensions of lintels as well as longitudinal transverse reinforcement shall not be less than those given in **10.4.2.1** for horizontal bond beams.

10.4.2. Horizontal Bond Beams

10.4.2.1 – Reinforced concrete horizontal bond beams satisfying the following conditions shall be made at places where slabs, including stair landings, are supported by walls such that they shall be cast monolithically with the reinforced concrete slabs.

(a) Width of horizontal bond beams shall be equal to the width of wall, and their height shall not be less than 20 cm.

(b) Concrete quality for bond beams shall be at least **C16 (BS16)**. Longitudinal reinforcement shall be at least **6Ø10** on stone walls with three at the bottom and three at the top, whereas it shall be at least **4Ø10** on other load-bearing walls with **Ø8** hoops with a maximum spacing of 25 cm. Longitudinal rebars shall be appropriately overlapped at the corners and intersections to achieve continuity (**Fig. 10.4**).

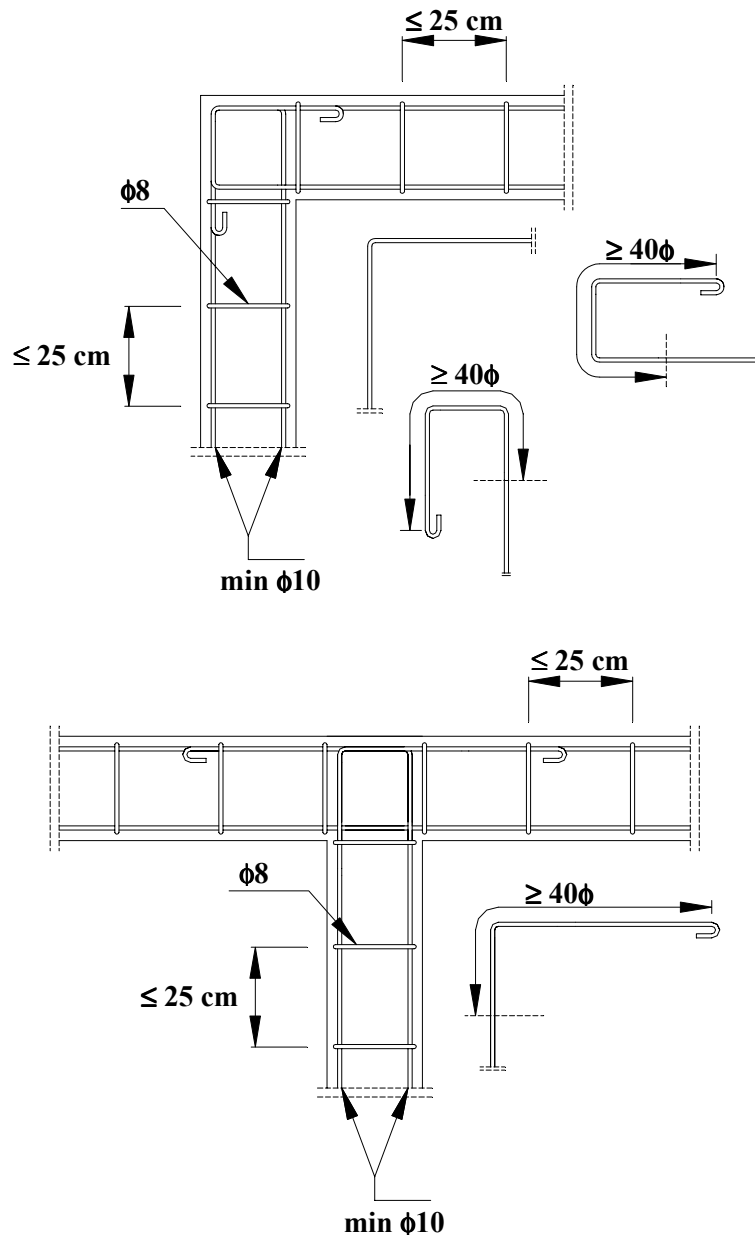

Figure 10.4

10.4.2.2 – In rubble stone walls, reinforced concrete horizontal bond beams shall be made excluding the slab and stair landing levels in accordance with the rules given in **10.4.2.1** with vertical axis to axis spacing not more than 1.5 m.

10.4.3. Vertical Bond Beams

10.4.3.1 – In order to enhance the earthquake resistance of masonry buildings, it shall be appropriate to construct reinforced concrete vertical bond beams in full storey height on the corners of buildings, along the vertical intersections of the load-bearing walls and on both sides of the door and window openings.

10.4.3.2 – Vertical bond beams shall be constructed by reinforcing and concreting the section in between the formworks to be placed parallel to the walls, following the construction of walls on both sides (**Fig. 10.5**).

10.4.3.3 – Cross section dimensions of vertical bond beams shall be equal to thicknesses of walls intersecting at corners and at the intersections of walls. In vertical bond beams to be constructed on both sides of window and door openings, cross section dimensions of the beam perpendicular to the wall shall not be less than the wall thickness, whereas the other cross section dimension shall not be less than 20 cm.

10.4.3.4 – Concrete quality for vertical bond beams shall be at least **C16 (BS16)**. Longitudinal reinforcement shall be at least **6Ø12** in stone walls with three at each wall face, whereas it shall be at least **4Ø12** in other load-bearing walls with **Ø8** hoops with a maximum spacing of 20 cm. Longitudinal starter bars shall be provided at the foundation and at the intermediate floors, and development of the ends of rebars shall be provided to achieve continuity (**Fig. 10.5**).

10.5. SLABS

10.5.1 – Reinforced concrete plate type slabs or joist floors dimensioned and reinforced in accordance with the requirements of TS-500 shall be used in masonry buildings.

10.5.2 – Masonry buildings with slabs other than those defined in **10.5.1** above, shall be constructed in all seismic zones with maximum two stories excluding the basement, if any. In such buildings, horizontal bond beams supporting the slabs shall also be constructed in accordance with **10.4.2**.

10.5.3 – Cantilever elements such as balconies, cornices and eaves of roofs shall be made only as an extension of floor slabs and the clear cantilever length shall not be more than 1.5 m. Clear cantilever length of cantilevered stairs shall be at most 1.0 m.

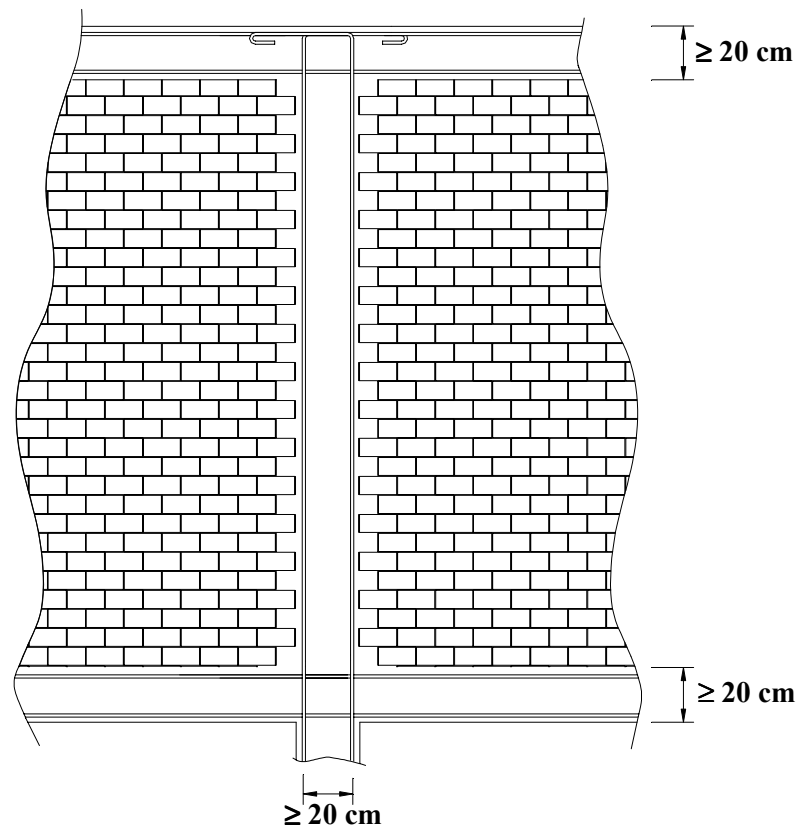

Figure 10.5

10.6. ROOFS

10.6.1 – Roofs of the masonry buildings may be constructed as reinforced concrete terrace roof, timber or steel truss roof bearing on roof slab.

10.6.2 – Connections of the timber roof elements to the roof slabs or to horizontal bond beams on bearing walls shall be made in accordance with the rules given in TS-2510.

10.6.3 – In the case where the height of the end wall resting on the horizontal bond beam at the top storey exceeds 2 m, vertical and inclined bond beams shall be constructed (**Fig. 10.6**).

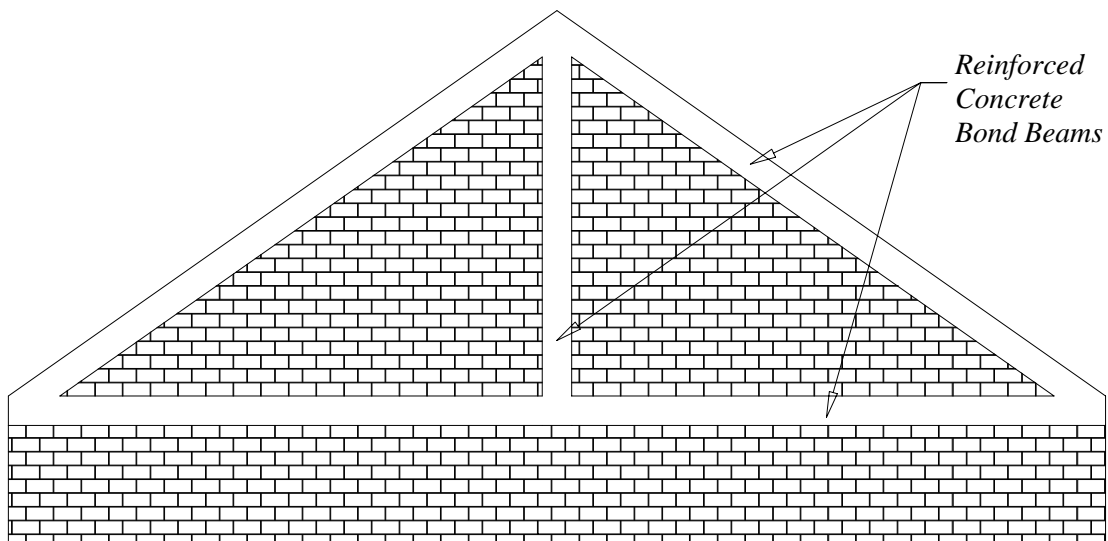

Figure 10.6

10.7. NON-BEARING WALLS

10.7.1 – Thickness of non-bearing partition walls shall be at least 1/2 brick size or at least 10 cm for non-brick material. Such walls shall be constructed by connecting to load-bearing wall on both edges along the vertical intersection. At least 1 cm gap shall be allowed between the top of the wall and floor bottom of the top slab, however necessary measures shall be taken to prevent the toppling of wall under the out-of-plane seismic loads.

10.7.2 – Height of parapets on terraces made of masonry wall material shall not be more than 60 cm.

10.7.3 – Height of garden walls made of masonry wall material shall not be more than 1.0 m from the pavement level.

CHAPTER 11 - EARTHQUAKE RESISTANT DESIGN REQUIREMENTS FOR ADOBE BUILDINGS

11.1. SCOPE

Dimensioning and reinforcing of adobe buildings to be constructed in seismic zones with adobe load-bearing walls to resist both vertical and lateral loads shall be performed, along with currently enforced relevant standards and codes, primarily in accordance with the requirements of this chapter.

11.2. GENERAL RULES

11.2.1 – All the rules given in this chapter for the dimensioning of adobe buildings shall be followed and an analysis based on **Chapter 6** shall not be performed.

11.2.2 – In all seismic zones, adobe buildings shall be constructed with a single storey excluding a basement. Buildings with Importance Factor according to **Table 6.3** of **Chapter 6** more than **I = 1** shall not be made of adobe construction.

11.2.3 – Height of the single storey adobe building shall not be more than 2.70 m from ground to the rooftop. In the case where a basement is made, height of this shall not be more than 2.40 m.

11.2.4 – Adobe buildings shall be rectangular in plan and load-bearing walls shall be arranged symmetric or nearly symmetric with respect to the main axes. Partial basement shall not be constructed.

11.3. FOUNDATIONS AND LOAD-BEARING WALLS

11.3.1. Foundations

11.3.1.1 – Foundations shall be made as rubble wall with a thickness of at least 50 cm in buildings without basement, and at least 60 cm in buildings with basement.

11.3.1.2 – Foundation depth shall be at least 80 cm, provided that it is below the frost depth. Foundation walls shall be extended up to 50 cm above the external ground level.

11.3.1.3 – Mortars to be used in foundation walls shall be cement mortar (*cement/sand volumetric ratio=1/4*) or lime mortar enhanced with cement (*cement/lime/sand volumetric ratio=1/2/9*).

11.3.2. Load-Bearing Wall Material

11.3.2.1 – Adobe bricks to be used in load-bearing walls shall be produced in accordance with TS-2514, and fallow adobe mortar shall be used in wall construction.

11.3.2.2 – Nominal adobe brick dimensions, in cm, shall be 12x30x40 (*main*) and 12x19x40 (*lamb*), or 12x18x30 (*main*) and 12x25x30 (*lamb*).

11.3.2.3 – Mortars to be used in rubble basement walls shall be lime mortar enhanced with cement (*cement/lime/sand volumetric ratio=1/2/9*) in the first and second seismic zones. Lime mortar (*lime/sand volumetric ratio=1/3*) may be used in the third and fourth seismic zones.

11.3.3. Minimum Thickness of Load-Bearing Walls

11.3.3.1 – External adobe load-bearing walls shall be at least 1.5 brick size, whereas internal adobe load-bearing walls shall be at least 1 brick size.

11.3.3.2 – Thickness of rubble stone walls of basement shall be at least 50 cm.

11.3.4. Minimum Total Length of Load-Bearing Walls

The ratio of the total length of adobe load-bearing walls in each of the orthogonal directions in plan (excluding window and door openings), to gross floor area (excluding cantilever floors) shall not be less than **0.25** m/m².

11.3.5. Maximum Unsupported Length of Load-Bearing Walls

Unsupported length of a load-bearing wall between the connecting wall axes in the perpendicular direction shall not exceed 4.5 m.

11.3.6. Openings in Load-Bearing Walls

The following rules shall be followed to provide openings in load-bearing walls:

11.3.6.1 – Plan length of the load-bearing wall segment between the corner of a building and the nearest window or door opening to the corner shall not be less than 1.0 m.

11.3.6.2 – Excluding the corners of buildings, plan lengths of the load-bearing wall segments between the window or door openings shall not be less than 1.0 m.

11.3.6.3 – In the case where two posts with cross section of 10 cm x 10 cm are placed on both sides of the window or door openings, minimum length of wall segments given in **11.3.6.2** may be decreased to 0.80 m. Posts to be placed shall be connected to the bond beam below the window and lintel above the window.

11.3.6.4 – Excluding the corners of buildings, plan length of a load-bearing wall segment between intersection of the orthogonal walls and the nearest window or door opening shall not be less than 0.5 m.

11.3.6.5 – Door openings shall not be more than 1.00 m in horizontal, not more than 2.10 m in vertical direction. More than one door opening shall not be made between the axes of intersecting walls in perpendicular direction.

11.3.6.6 – Window openings shall not be more than 0.90 m in horizontal, not more than 1.20 m in vertical direction.

11.4. LINTELS AND BOND BEAMS

11.4.1. Lintels

11.4.1.1 – Lintels shall be made at the top of doors and at the bottom and top of windows with two timber elements of square sections of 10 cm x 10 cm.

11.4.1.2 – Each of seating lengths of window and door lintels on the walls shall not be less than 20 cm.

11.4.2. Bond Beams

11.4.2.1 – Reinforced concrete or timber bond beams shall be made as defined below on the foundation walls or basement walls in buildings with basement.

(a) Reinforced concrete bond beams shall have a thickness equal to that of wall and a height of at least 15 cm. Quality of concrete to be used shall be at least **C14 (BS14)** (minimum dosage: 250 kg/m³) with longitudinal reinforcement being at least **6Ø10** with three at the bottom and three at the top and **Ø8** hoops with a maximum spacing of 25 cm.

(b) Timber bond beams shall be tar emulsified two elements of square sections of 10 cm x 10 cm which are to be placed with outer faces coinciding with the exterior and interior wall surfaces. These pieces shall be tied each other at every 50 cm with nail jointed timber elements of cross section of 5 cm x 10 cm and holes in between shall be filled with stone aggregate.

11.4.2.2 – Rules for the bond beams to be constructed on top of adobe walls at roof level are given in the following.

(a) In the case where the roof is made of timber truss or as a soil roof in accordance with **11.5.2** below, bond beams at roof level shall be made in accordance with para.**(b)** of **11.4.2.1**.

(b) In the case where the roof is made as a reinforced concrete plate, reinforced concrete bond beams of at least 20 cm height shall be constructed at roof level. Quality of concrete to be used shall be at least **C14 (BS14)** (minimum dosage: 250 kg/m³) with longitudinal reinforcement being at least **4Ø10** and **Ø8** hoops with a maximum spacing of 25 cm.

11.5. ROOFS

11.5.1 – Roofs of the adobe buildings shall be made as light as possible with eaves extending from the outer wall by at most 50 cm.

11.5.2 – Soil roofs shall not be made in the first and second seismic zones. In the third and fourth seismic zones, thickness of soil roof shall not exceed 15 cm.

11.5.3 – Roofs of the adobe buildings may also be made of timber truss or as a reinforced concrete terrace floor.

CHAPTER 12 – FOUNDATION SOILS AND EARTHQUAKE RESISTANT DESIGN REQUIREMENTS FOR FOUNDATIONS

12.0. NOTATION

A_o	= Effective Ground Acceleration Coefficient defined in Chapter 6 .
C_h	= Equivalent lateral seismic coefficient used in determining the soil pressure
C_v	= Equivalent vertical seismic coefficient used in determining the soil pressure
H	= Total height of uniform soil deposit or sum of layer thicknesses in layered soils
h_1	= Thickness of the topmost soil layer
I	= Building Importance Factor defined in Chapter 6 .
i	= Slope angle of the soil surface measured upwards on the side of active or passive pressure
K_{as}	= Static active pressure coefficient
K_{ad}	= Dynamic active pressure coefficient
K_{at}	= Total active pressure coefficient
K_{ps}	= Static passive pressure coefficient
K_{pd}	= Dynamic passive pressure coefficient
K_{pt}	= Total passive pressure coefficient
P_{ad}	= Resultant of dynamic active pressure due to soil mass
P_{pd}	= Resultant of dynamic passive pressure due to soil mass
$p_{ad}(z)$	= Variation of dynamic active pressure due to soil mass with respect to depth
$p_{pd}(z)$	= Variation of dynamic passive pressure due to soil mass with respect to depth
$p_v(z)$	= Variation of vertical soil pressure with respect to depth
Q_{ad}	= Resultant of dynamic active pressure due to uniformly distributed surcharge
Q_{pd}	= Resultant of dynamic passive pressure due to uniformly distributed surcharge
$q_{ad}(z)$	= Variation of dynamic active pressure due to uniformly distributed surcharge with respect to depth
$q_{pd}(z)$	= Variation of dynamic passive pressure due to uniformly distributed surcharge with respect to depth
q_o	= Amplitude of uniformly distributed surcharge
R_{za}	= Reduction factor used in determining the dynamic internal forces applicable to section design of retaining walls
z	= Depth measured downwards from free soil surface
z_{cd}	= Depth of the resultant of active or passive pressure measured downwards from free soil surface
α	= Angle of wall-soil interface with vertical towards active or passive pressure
δ	= Friction angle between soil and wall
ϕ	= Internal friction angle of soil
\emptyset	= Rebar diameter
γ	= Dry unit weight of soil
γ_b	= Submerged unit weight of soil
γ_s	= Saturated unit weight of soil
λ	= An angle calculated for determining total active and passive pressure coefficients in terms of equivalent seismic coefficients

12.1. SCOPE

Determination of soil conditions of buildings to be constructed in seismic zones; design of reinforced concrete, structural steel, timber and masonry building foundations and soil retaining structures shall be performed, along with the applicable codes and standards in relevant areas, primarily in accordance with the rules and requirements of this chapter. Rules for the foundations of adobe buildings are given in **Chapter 11**.

12.2. DETERMINATION OF SOIL CONDITIONS

12.2.1. Soil Groups and Local Site Classes

12.2.1.1 – Soil groups and local site classes to be considered as the bases of determination of local soil conditions are given in **Table 12.1** and **Table 12.2**, respectively. Values of soil parameters in **Table 12.1** are to be considered as standard values given for guidance only in determining the soil groups.

12.2.1.2 – Soil investigations based on appropriate site and laboratory tests are mandatory to be conducted for below given buildings with related reports prepared and attached to design documents. Soil groups and local site classes to be defined in accordance with **Table 12.1** and **Table 12.2** shall be clearly indicated in reports.

(a) All buildings with total height exceeding 60 m in the first and second seismic zones,

(b) Irrespective of the building height, buildings in all seismic zones with Building Importance Factor of **I=1.5** and **I=1.4** according to **Table 6.3** of **Chapter 6**.

12.2.1.3 – Regarding the buildings outside the scope of above given **12.2.1.2**, in the first and second seismic zones, available local information or observation results shall be included or published references shall be quoted in the seismic analysis reports to identify the soil groups and local site classes in accordance with **Table 12.1** and **Table 12.2**.

12.2.1.4 – In the first and second seismic zones, horizontal bedding parameters as well as horizontal and vertical load carrying capacities of piles under seismic loads in Group **(C)** and **(D)** soils according to **Table 12.1** shall be determined on the basis of soil investigations including in-situ and laboratory tests.

12.2.2. Investigation of Liquefaction Potential

In all seismic zones, Group **(D)** soils according to **Table 12.1** with water table less than 10 m from the the soil surface shall be investigated and the results shall be documented to identify whether the *Liquefaction Potential* exists, by using appropriate analytical methods based on in-situ and laboratory tests.

TABLE 12.1 - SOIL GROUPS

<i>Soil Group</i>	<i>Description of Soil Group</i>	<i>Stand. Penetr. (N/30)</i>	<i>Relative Density (%)</i>	<i>Unconf. Compres. Strength (kPa)</i>	<i>Shear Wave Velocity (m/s)</i>
(A)	1. Massive volcanic rocks, unweathered sound metamorphic rocks, stiff cemented sedimentary rocks	—	—	> 1000	> 1000
	2. Very dense sand, gravel...	> 50	85–100	—	> 700
	3. Hard clay, silty lay.....	> 32	—	> 400	> 700
(B)	1. Soft volcanic rocks such as tuff and agglomerate, weathered cemented sedimentary rocks with planes of discontinuity.....	—	—	500–1000	700–1000
	2. Dense sand, gravel.....	30–50	65–85	—	400–700
	3. Very stiff clay, silty clay..	16–32	—	200–400	300–700
(C)	1. Highly weathered soft metamorphic rocks and cemented sedimentary rocks with planes of discontinuity	—	—	< 500	400–700
	2. Medium dense sand and gravel.....	10–30	35–65	—	200–400
	3. Stiff clay, silty clay.....	8–16	—	100–200	200–300
(D)	1. Soft, deep alluvial layers with high water table.....	—	—	—	< 200
	2. Loose sand.....	< 10	< 35	—	< 200
	3. Soft clay, silty clay.....	< 8	—	< 100	< 200

TABLE 12.2 - LOCAL SITE CLASSES

<i>Local Site Class</i>	<i>Soil Group according to Table 12.1 and Topmost Layer Thickness (h₁)</i>
Z1	Group (A) soils Group (B) soils with h₁ ≤ 15 m
Z2	Group (B) soils with h₁ > 15 m Group (C) soils with h₁ ≤ 15 m
Z3	Group (C) soils with 15 m < h₁ ≤ 50 m Group (D) soils with h₁ ≤ 10 m
Z4	Group (C) soils with h₁ > 50 m Group (D) soils with h₁ > 10 m

NOTES ON TABLE 12.2 :

(a) *In the case where the thickness of the topmost soil layer under the foundation is less than 3 m, the layer below may be considered as the topmost soil layer indicated in Table 12.2.*

(b) *In the case where the foundation system is comprised of vertical or inclined piles with $1/6$ and less inclination with respect to vertical, the topmost soil layer indicated in Table 12.2 may be deemed to be the layer at the tip of the shortest pile. However in such a case piles shall be taken into account as structural elements together with the superstructure in the seismic analysis to be performed in accordance with Chapter 6, or horizontal and vertical pile stiffnesses shall be modelled with equivalent springs under the pile caps. It is essential that horizontal and vertical bedding of piles to the soil (soil-pile interaction) and the pile group effects be considered in the analysis together with stiffness and inertia properties of pile caps and tie beams.*

(c) *In cases where conditions given in para (b) above are not satisfied or pile inclination with respect to vertical exceeds $1/6$ in the third and fourth seismic zones in accordance with 12.3.3.1, the topmost soil layer indicated in Table 12.2 shall be taken as the first layer under the pile caps.*

12.3. RULES AND REQUIREMENTS FOR FOUNDATIONS

12.3.1. General Rules

Building foundations shall be constructed on the bases of principles of soil mechanics and foundation engineering, by considering the properties of underlying soils such that any damage in the superstructure due to settlement or differential settlement during earthquake is avoided. Rules given in this chapter for foundations are applicable to the foundations of reinforced concrete, structural steel, timber and masonry buildings. Rules for the foundations of adobe buildings are given in Chapter 11.

12.3.2. Allowable Soil Pressures and Allowable Load Capacities of Piles

12.3.2.1 – The allowable soil pressure and allowable horizontal and axial load capacities of piles specified for static loads may be increased in the case of seismic loading by at most 50% for foundation soils classified as Group (A), (B) and (C) in Table 12.1.

12.3.2.2 – The allowable soil pressure and allowable load capacities of piles shall not be increased in the case of seismic loading for foundation soils classified as Group (D) in Table 12.1.

12.3.3. Requirements for Piled Foundations

12.3.3.1 – Inclined piles with more than $1/6$ inclination with respect to vertical shall not be used in the first and second seismic zones.

12.3.3.2 – Pile foundations shall be analysed for earthquake induced lateral loads in addition to axial loads.

12.3.3.3 – In the first and second seismic zones, longitudinal reinforcement ratio of cast-in-situ cased or uncased bored piles shall not be less than 0.008 within the top 1/3 of the pile length under the pile cap, which shall not be less than 3 m. Diameter of spiral reinforcement to be provided within this length shall not be less than 8 mm and the pitch of spirals shall not be more than 200 mm which shall be reduced to 100 mm within a length of at least twice the pile diameter from the top.

12.3.3.4 – Longitudinal reinforcement ratio of reinforced concrete precast driven piles shall not be less than 0.01. In the first and second seismic zones, diameter of transverse reinforcement within the top 1/3 of the pile length under the pile cap shall not be less than 8 mm. Hoop spacing or pitch of spirals within this length shall not be more than 200 mm which shall be reduced to 100 mm within a length of at least twice the pile diameter (twice the greatest dimension of piles with rectangular cross-section) from the top. Transverse reinforcement requirements shall be equally applicable to prestressed precast driven piles.

12.3.4. Foundation Tie Beams

12.3.4.1 – In reinforced concrete and structural steel buildings, tie beams shall be provided to connect individual footings or pile caps in both directions or to connect continuous foundations at column or structural wall axes. Tie beams may be omitted or their numbers may be reduced on soils classified as Group (A) in **Table 12.1**.

12.3.4.2 – Consistent with the foundation excavation, tie beams may be constructed at any level between the bottom of the foundation and the bottom of the column.

12.3.4.3 – The minimum requirements to be satisfied by tie beams are given in **Table 12.3** depending on the seismic zone of the building and the soil groups defined in **Table 12.1**.

TABLE 12.3 – MINIMUM REQUIREMENTS FOR TIE BEAMS

DESCRIPTION OF REQUIREMENT	Seismic Zone	Soil Group (A)	Soil Group (B)	Soil Group (C)	Soil Group (D)
1. Minimum axial force of tie beam (*)	1, 2 3, 4	%6 %4	%8 %6	%10 %8	%12 %10
2. Minimum cross-section dimension (cm) (**)	1, 2 3, 4	25 25	25 25	30 25	30 25
3. Minimum cross-section area (cm²)	1, 2 3, 4	625 625	750 625	900 750	900 750
4. Minimum longitudinal reinforcement	1, 2 3, 4	4Ø14 4Ø14	4Ø16 4Ø14	4Ø16 4Ø16	4Ø18 4Ø16

(*) *As a percentage of the greatest axial force of columns or structural walls connected by tie beams*

(**) *The minimum cross-section dimension shall not be less than 1/30 of the clear span of the tie beam.*

12.3.4.4 – Tie beams shall be considered in the cross-section design as resisting against both compression and tension forces. In the case of resistance against compression, buckling effect may be neglected in tie beams confined by soil or on-grade concrete. Hoop diameter of tie beams shall not be less than 8 mm and their spacing shall not be more than 200 mm.

12.3.4.5 – Tie beams may be replaced by reinforced concrete slabs. In such a case slab thickness shall not be less than 150 mm. It shall be demonstrated by calculation that the slab and its reinforcement safely transfer the forces equal to those given for tie beams in **Table 12.3**.

12.3.5. Under-wall Foundations of Timber and Masonry Buildings

12.3.5.1 – Foundations of timber and masonry buildings shall be constructed as reinforced concrete continuous foundations under the load bearing walls. Depth of an under-wall foundation shall be determined by considering the soil characteristics, groundwater level and the local frost depth. In buildings without basement, top level of stone or concrete walls to be constructed on the foundations shall be at least 50 cm above the pavement level.

12.3.5.2 – Concrete quality of under-wall foundations shall be at least **C16 (BS16)**. Requirements on the dimensions and the reinforcement of under-wall foundations are given in **Table 12.4** depending on the soil groups defined in **Table 12.1**.

12.3.5.3 – Stepped foundations may be constructed on sloped ground made of soils classified in **Table 12.1** as Group **(A)**, **(B)** or **(C)**. Requirements for stepped foundations are also given in **Table 12.4**.

12.3.5.4 – Lateral spacing between the longitudinal rebars to be placed at top and bottom of the under-wall foundations shall not exceed 30 cm; appropriate overlapping shall be provided to achieve continuity at corners, junctions and in stepped foundations.

TABLE 12.4 – REQUIREMENTS FOR UNDER-WALL FOUNDATIONS

<i>DESCRIPTION OF REQUIREMENT</i>	<i>Soil Group (A),(B)</i>	<i>Soil Group (C)</i>	<i>Soil Group (D)</i>
Minimum foundation width (cm)	50	60	70
Protrusion width (from both sides) to be added to wall thickness (cm)	2 x 15	2 x 20	2 x 25
Minimum foundation height (cm)	30	40	40
Minimum top and bottom longitudinal reinforcement	3Ø12	3Ø14	4Ø14
Minimum hoop requirement at foundations	Ø8/30	Ø8/30	Ø8/30
Minimum lateral spacing of steps (cm)	100	150	–
Minimum step overlapping length (cm)	30	40	–
Maximum step height (cm)	30	30	–

12.4. SEISMIC SOIL PRESSURES AND SOIL RETAINING STRUCTURES

12.4.1. Total Active and Passive Pressure Coefficients

12.4.1.1 – Total Active Pressure Coefficient, K_{at} , and Total Passive Pressure Coefficient, K_{pt} , which shall be used to calculate static soil pressure plus additional dynamic soil pressure induced by earthquake are given by Eq.(12.1), by neglecting the soil cohesion to remain on the conservative side.

$$K_{at} = \frac{(1 \pm C_v) \cos^2(\varphi - \lambda - \alpha)}{\cos\lambda \cos^2\alpha \cos(\delta + \alpha + \lambda)} \times \frac{1}{\left[1 + \sqrt{\frac{\sin(\varphi + \delta) \sin(\varphi - \lambda - i)}{\cos(\delta + \alpha + \lambda) \cos(i - \alpha)}} \right]^2} \quad (12.1a)$$

$$K_{pt} = \frac{(1 \pm C_v) \cos^2(\varphi - \lambda + \alpha)}{\cos\lambda \cos^2\alpha \cos(\delta - \alpha + \lambda)} \times \frac{1}{\left[1 - \sqrt{\frac{\sin(\varphi + \delta) \sin(\varphi - \lambda + i)}{\cos(\delta - \alpha + \lambda) \cos(i - \alpha)}} \right]^2} \quad (12.1b)$$

12.4.1.2 - The angle λ in Eq.(12.1) is defined by Eq.(12.2).

(a) For dry soils,

$$\lambda = \arctan \left[\frac{C_h}{(1 \pm C_v)} \right] \quad (12.2a)$$

(b) For submerged soils,

$$\lambda = \arctan \left[\frac{\gamma_s}{\gamma_b} \times \frac{C_h}{(1 \pm C_v)} \right] \quad (12.2b)$$

12.4.1.3 – In the case of submerged or saturated soils, δ in Eq.(12.1) shall be replaced by $\delta/2$.

12.4.1.4 – Equivalent lateral seismic coefficient, C_h , appearing in Eq.(12.2) is defined by Eq.(12.3).

(a) In soil retaining structures behaving as vertical free cantilevers,

$$C_h = 0.2 (I + 1) A_o \quad (12.3a)$$

(b) In soil retaining structures and elements horizontally restrained by building floors or soil anchors,

$$C_h = 0.3 (I + 1) A_0 \quad (12.3b)$$

12.4.1.5 - Equivalent vertical seismic coefficient, C_v , appearing in Eq.(12.1) and Eq.(12.2) is defined by Eq.(12.4). However, it shall be $C_v = 0$ in basement walls which are horizontally restrained by building floors.

$$C_v = 2 C_h / 3 \quad (12.4)$$

The cases $+C_v$ or $-C_v$ shall be considered as consistent with Eq.(12.2) to yield more unfavourable lateral soil pressure by Eq.(12.1).

12.4.2. Dynamic Active and Passive Soil Pressures

12.4.2.1 – Dynamic active pressure coefficient, K_{ad} , and dynamic passive pressure coefficient, K_{pd} , induced by earthquake shall be determined by Eq.(12.5).

$$K_{ad} = K_{at} - K_{as} \quad (12.5a)$$

$$K_{pd} = K_{pt} - K_{ps} \quad (12.5b)$$

Static active pressure coefficient, K_{as} , and static passive pressure coefficient, K_{ps} , appearing in Eq.(12.5) may be obtained by substituting $\lambda = 0$ and $C_v = 0$ in Eq.(12.1).

12.4.2.2 – Variation of dynamic active and passive pressures along the depth of soil which are induced in addition to static soil pressure by the soil mass during earthquake are defined by Eq.(12.6).

$$p_{ad}(z) = 3 K_{ad} (1 - z / H) p_v(z) \quad (12.6a)$$

$$p_{pd}(z) = 3 K_{pd} (1 - z / H) p_v(z) \quad (12.6b)$$

In the case of uniform soil in dry, the positive value of the resultant P_{ad} of dynamic active soil pressure and the negative value of the resultant P_{pd} of dynamic passive soil pressure which are induced by earthquake in addition to static soil pressure and the depths of such resultants measured from the top soil level, z_{cd} , are obtained as given by Eq.(12.7) and Eq.(12.8), respectively, by integrating Eq.(12.6) along the soil depth by taking $p_v(z) = \gamma z$:

$$P_{ad} = 0.5 \gamma K_{ad} H^2 \quad (12.7a)$$

$$P_{pd} = 0.5 \gamma K_{pd} H^2 \quad (12.7b)$$

$$z_{cd} = H / 2 \quad (12.8)$$

In the case of submerged soil, γ_b shall be considered in lieu of γ in determining $p_v(z)$ and hydrodynamic pressure of water shall not be calculated additionally. In the case of saturated soil, γ_s shall be used in lieu of γ .

12.4.2.3 – Variation of dynamic active and passive pressures along the depth of soil which are induced in addition to static soil pressure by uniformly distributed surcharge during earthquake are defined by Eq.(12.9).

$$q_{ad}(z) = 2 q_0 K_{ad} (1 - z/H) \cos \alpha / \cos(\alpha - i) \quad (12.9a)$$

$$q_{pd}(z) = 2 q_0 K_{pd} (1 - z/H) \cos \alpha / \cos(\alpha - i) \quad (12.9b)$$

In the case where soil characteristics are uniform, the resultants Q_{ad} and Q_{pd} of active (positive) and passive (negative) soil pressures which are induced by earthquake in addition to static soil pressure and the depths of such resultants measured from the top soil level, z_{cd} , are obtained as given by Eq.(12.10) and Eq.(12.11), respectively, by integrating Eq.(12.9) along the soil depth

$$Q_{ad} = q_0 K_{ad} H \cos \alpha / \cos(\alpha - i) \quad (12.10a)$$

$$Q_{pd} = q_0 K_{pd} H \cos \alpha / \cos(\alpha - i) \quad (12.10b)$$

$$z_{cd} = H / 3 \quad (12.11)$$

12.4.3. Dynamic Soil Pressures in Layered Soils

Expressions given above by Eq.(12.6) ve Eq.(12.9) can be applied also for case of layered soils. In such a case, the coefficients K_{ad} or K_{pd} pertinent for the layer concerned shall be used and the depth z shall always be measured downwards from the free soil surface. Resultants of dynamic active or passive pressures of each layer and their depths within the layer may be obtained by integrating Eq.(12.6) and Eq.(12.9) along the depth of the relevant layer.

12.4.4. Requirements for Soil Retaining Structures

12.4.4.1 – In the seismic analysis of soil retaining structures behaving as vertical free cantilevers, seismic forces related to wall mass may not be considered in addition to horizontal soil pressure. In the analysis performed by considering dynamic soil pressures given by Eq.(12.6) and Eq.(12.9) in addition to static soil pressures, safety factor against sliding shall be taken at least **1.1** and safety factor against overturning shall be taken at least **1.3**.

12.4.4.2 – Internal forces to be taken into account in the cross section design of reinforced concrete retaining walls and reinforced concrete or steel sheetpile walls shall be the internal forces induced by static soil pressures plus those obtained by dividing by $R_{za} = 1.5$ of the internal forces induced by dynamic soil pressures given by Eq.(12.6) and Eq.(12.9). It may be taken $R_{za} = 2.5$ for temporary steel sheetpile walls.

CHAPTER 13 – FINAL CLAUSES

13.1 – “Specification for Structures to be Built in Disaster Areas” published in the Official Gazette No. 22635 (repeated) dated 13.5.1996 is annulled.

13.2 – This Specification shall be put into effect on the date 1.1.1998.

13.3 – Until the date of this Specification is put into effect, “Specification for Structures to be Built in Disaster Areas” published in the Official Gazette No. 15260 dated 9.6.1975 shall be applied.

13.4 – The clauses of this Specification are administered by the Minister of Public Works and Settlement.